



City of Meriden, Connecticut

Purchasing Department

Invitation to Bid

For

IT Wiring at the Meriden Public Library

Meriden, CT

B023-24

Proposals Due: December 6, 2022 @ 11:00 AM

Purchasing Department

142 East Main Street, Room 210

Meriden, CT 06450

(203) 630-4115

LEGAL NOTICE

INVITATION TO BID

The City of Meriden is accepting sealed bids for:

B023-24 – IT Wiring at the Meriden Public Wiring

The City of Meriden seeks the services of a contractor to furnish labor and materials to wire CAT-6 cable on the second floor of the Meriden Public Library, 105 Miller Street, Meriden, CT 06450.

Bids shall be submitted on forms and in the manner specified. Forms and specifications may be obtained from the Purchasing Department, on the City of Meriden website (www.meridenct.gov/business/bids-rfps/), and on the State of Connecticut Department of Administrative Services website (<https://portal.ct.gov/DAS/CTSource>). Bids will be accepted at the Purchasing Department, 142 East Main Street, Room 210, Meriden, Connecticut 06450 until **11:00 AM local, Eastern Standard Time on December 6, 2022** at which time they will be publicly opened and read. Any bid received after the time and date specified shall not be considered.

The right is reserved to reject any or all bids, in whole or in part, to award any item, group of items, or total bid, and to waive informality or technical defects, if it is deemed to be in the best interest of the City of Meriden. No bidder may withdraw its bid within sixty (60) days of the date of the bid opening.

There will be a Non-Mandatory Pre-Bid Meeting on Tuesday, November 22, 2022 at 10:00 AM at the Meriden Public Library, 105 Miller Street, Meriden CT 06450. Please meet by the Miller Street Gate. Do not enter the building without City of Meriden Purchasing/IT Staff as the building is undergoing renovation.

The attention of bidders is call to the requirement for minimum wage rates to be paid under this contract.

The City of Meriden is an Affirmative Action/Equal Opportunity Employer. Disadvantaged, minority, small, and women business enterprises are encouraged to respond.

Adam B. Tulin
Purchasing Officer
City of Meriden, CT 06450-8022
Dated: November 15, 2022

CITY OF MERIDEN, CONNECTICUT

B023-24 – IT Wiring at the Meriden Public Library

INFORMATION TO BIDDERS

1. BIDDING PROCEDURES

Sealed Bids shall be submitted on the forms designated by the attached proposal bid forms. Bids will be received by the City of Meriden’s Purchasing Department, Room 210, City Hall, 142 East Main Street, Meriden, Connecticut, 06450-8022 until 11:00 AM on December 6, 2022 and thereafter immediately read in public (the “bid opening”).

2. BIDS

Bids are to be submitted on the attached proposal forms. Please submit two copies of the proposal forms and Bidder’s Qualification Statement. One shall be an original and one can be a copy. **Please submit one complete copy of your bid on a flash drive.**

BID WILL BE AUTOMATICALLY REJECTED FOR ANYONE SUBMITTING A SURETY OTHER THAN THOSE SPECIFIED.

- a. Bids must be made out and signed in the corporate, or other, name of Bidder, and must be fully and properly executed by an authorized person.
- b. The sealed envelope must denote the Bidder’s name and address in the upper left hand corner and the words “BID DOCUMENT – B023-24 – IT Wiring at the Meriden Public Library to be opened at 11:00 AM” in the lower left hand corner.
- c. Bids received later than the time and date specified will not be considered.
- d. Amendments to or withdrawal of bids received later than the date and time set forth in the bid opening will not be considered.
- e. All prices must be in ink or typewritten. In the event of a bidder’s mathematical error in tabulating any bid prices, *the written unit prices shall govern.*

3. BIDDER QUALIFICATIONS

Bidders will be required to fill out, and include as part of its bid, any attached Bidder’s Qualification Statement.

In determining the qualifications of a bidder, the City of Meriden will consider the bidder’s record of performance in any prior contracts for construction work. The City of Meriden expressly reserves the right to reject a bid if the bidder’s historical performance, in the sole opinion of the City of Meriden, has been unsatisfactory in any manner or if the bidder has habitually and without just cause neglected the payment of bills or has otherwise disregarded its obligations to subcontractors, suppliers, or employees.

4. EXAMINATION OF BIDDING DOCUMENTS

Bidders are to examine all documents and visit the site in order to make a thorough examination of the conditions so that the bidder may familiarize itself with all of the existing requirements, conditions, and difficulties that will affect the execution of the work in order to determine the amount of work necessary to carry out the true intent of the specifications and work shown on the drawings.

The City of Meriden and its agents do not have any responsibility for the accuracy, completeness, or sufficiency of any bid document obtained from any other source other than from the City of Meriden. Obtaining documents from any other source(s) may result in obtaining incomplete and inaccurate information. Obtaining documents from any other source may also result in failure to receive any addenda, corrections, or other revisions to the documents that may be issued.

No request shall be honored if such request is made less than seven (7) calendar days prior to the date fixed for the opening of bids. Any and all such interpretations, and any supplementary instructions, will be in the form of a written addenda to the specifications which, if issued, will be made available on the City of Meriden website (www.meridenct.gov) unless it is to change the date fixed for the opening of bids, not later than three (3) days prior to the date fixed for the opening of bids. Bidders are encouraged to check the website regularly for addenda. Failure of any bidder to receive any such addenda shall not relieve any bidder from any obligations under its bid as submitted.

Any questions about the bid document must be submitted in writing via email to meridenpurchasing@meridenct.gov. Any other format of question will not be answered.

5. BIDS TO REMAIN OPEN

No bidder may withdraw its bid within sixty (60) days of the date of the bid opening. Should there be reason why the contract cannot be awarded within the specified period, the time may be extended by mutual agreement between the City of Meriden and the successful bidder.

6. AWARD OF CONTRACT

The Purchasing Officer reserves the right to make an award on the bid which, by the Purchasing Officer's judgment and recommendation from the IT Department following bid evaluations, best meets the specifications and is deemed to be in the best interest of the City of Meriden.

The contract will not be awarded to any corporation, firm, or individual which/who is in arrears to the City of Meriden by debt or contract, or who is in default as security or otherwise by any obligation to the City of Meriden.

The right is reserved to reject any or all bids, in whole or in part, to award any item, group of items, or total bid, and to waive informality or technical defects, if it is deemed to be in the best interest of the City of Meriden.

7. BID PROTEST PROCEDURE

In the event that any bidder wishes to protest the potential award of a bid, or any procedure of act in the advertising or soliciting of the bids, said bidder must make said protest in writing, which shall state the reason therefore and request a conference with respect thereto. Said protest must be received in the City Purchasing Office within **FIVE (5)** business days after the delivery of bid results or decisions. A conference with respect to said protest shall be scheduled by the Purchasing Officer forthwith and shall be attended by him or his designee and such other persons as the Purchasing Officer and the City Manager shall require to attend. The subject matter of said conference shall be limited to the reasons for the protest specified in the written request for said conference. Said conference shall also include a discussion of all possibilities for a resolution of dispute. The City shall make a decision in writing within three (3) business days after said conference and forward the same to the protesting bidder forthwith. In the event that any protesting bidder wishes to take legal action against the City, they must fully comply with all of these instructions to bidders.

8. CITY OF MERIDEN, LOCAL PREFERENCE

In determining the lowest responsible bidder, the Purchasing Department shall also consider Local Preference.

This section shall not apply in those instances where the bid requested involves a cooperative purchasing arrangement between the City of Meriden and other municipalities or the State of Connecticut.

Bidders are specifically advised that the City of Meriden has adopted Section 3-14 of the Code of the City of Meriden which requires, but is not limited to, a local preference requiring, in part, that a “City-based business” shall mean a business with its principal place of business located within the boundaries of the City of Meriden. A business shall not be considered a “City-based business” unless evidence has been submitted, satisfactory to the Purchasing Department, with each bid (forms included in bidding documents) to establish that the bidder has a bona fide principal place of business, operates out of, or pays property taxes on personal property in the City of Meriden.

Any City-based business bidder which has submitted a bid not more than ten (10) percent higher than the low bid provided such City-based business bidder agrees to accept the award of the bid at the amount of the low bid. The acceptance shall be submitted in writing to the Purchasing Department no later than next business day following the opening of the bid. For example, a bid opened at 11:00 a.m. on a Monday must be accepted by the City-based bidder no later than 11:00 a.m. on Tuesday. If more than one City-based business bidder has submitted bids not more than ten (10) percent higher than the low bid and has agreed to

accept the award of the bid at the amount of the low bid, the lowest responsible bidder shall be one of the City-based business bidders which has submitted the lowest bid.

Bidders claiming status under the local preference are hereby required to submit with its bid an additional form, titled "Request for Status as a Meriden Based Business."

9. EXTENSION OF AGREEMENT – N/A

10. TIME

Inasmuch as the contract concerns a public improvement, the provisions of the contract relating to the time of performance and completion of the work are of the essence of the contract. Accordingly, the successful bidder/contractor ("Contractor") shall begin work on the day specified in paragraph 2.04 of the General Conditions and shall perform the work diligently so as to permit full use not later than the first day following the construction period established in the Contract. See paragraph 10 entitled "Liquidated Damages" of the Agreement between City of Meriden, as owner, and the Contractor.

11. SCHEDULE OF WORK

The Contractor shall schedule all work in a manner that will not disrupt City of Meriden operations. Once the work has begun, the Contractor shall work full-time until completion of the Contract.

12. TAXES

The City of Meriden is exempt under Connecticut General Statutes from the payment of the excise taxes imposed by the federal government and the Sales and Use Tax of the State of Connecticut; such taxes should not be included in the bid price. Upon request, exemption certificates will be furnished to the successful bidder.

13. FAIR EMPLOYMENT PRACTICES

The Contractor shall agree that neither it or its subcontractors, except in the case of a bona fide occupational qualification or need, to refuse to hire or employ or to bar or to discharge from employment any individual or to discriminate against such individual in compensation or in terms, conditions or privileges of employment because of the individual's race, color, religious creed, age, sex, gender identity or expression, marital status, national origin, ancestry, present or past history of mental disability, intellectual disability, learning disability, physical disability, including, but not limited to, blindness or status as a veteran. The aforementioned terms are obtained from Connecticut General Statutes Section 46a-60, *et seq.*, entitled "Discriminatory employment practices prohibited," as amended.

14. FORM OF AGREEMENT BETWEEN CITY OF MERIDEN AND CONTRACTOR

The Agreement for the work will be written on the Agreement between City of Meriden and Contractor, wherein the basis of payment is a stipulated sum.

15. LOCAL SUBCONTRACTORS, SUPPLIERS, etc.

Local subcontractors, material suppliers, and labor in the City of Meriden should be considered and sought out insofar as it is practical in the performance of this project.

16. CITY OF MERIDEN CODE OF ETHICS

The City of Meriden has adopted a Code of Ethics located in Chapter 21 of the Code of the City of Meriden, sections 21-1 through 21-15, inclusive, which are expressly incorporated herein by reference. The terms of the Code of Ethics shall constitute a part of any contract or agreement entered into by the City of Meriden as a result of this bid as if those terms were fully set forth in such contract or agreement.

Bidders are specifically advised that the Code of Ethics prohibits public officers and employees, as well as their immediate families and businesses, with which they are associated from participating in any transaction which is incompatible with the proper discharge of official duties or responsibilities. Bidders are also advised that the Code of Ethics contain provisions with respect to paid contractors and former employees and officials.

BIDDERS SHOULD NOTE THAT BIDS, CONTRACTS, AND AGREEMENTS ENTERED INTO OR AWARDED IN VIOLATION OF THE CODE OF ETHICS ARE VOIDABLE BY RESOLUTION OF THE CITY COUNCIL OF THE CITY OF MERIDEN.

Copies of the Code of Ethics may be obtained from the office of the City Clerk or may be found online on the City of Meriden's website.

17. NON-COLLUSION BID STATEMENT

Each bidder submitting a bid to the City of Meriden for any portion of the work contemplated by the documents on which bidding is based shall execute and attach thereto the sworn Non-Collusive Bid Statement, to the effect that the bidder has not colluded with any other person, firm, or corporation in the submission of the bid.

18. SOIL CONDITIONS

The City of Meriden does not guarantee the accuracy of any information which it may have obtained as to the kind or condition of the soil that may be encountered in the performance of the proposed work; neither does the City of Meriden represent that the plans and specifications drawn are based upon any soil data so obtained. The City of Meriden does not

make any representations as to the soil data so obtained. The City of Meriden does not make any representations as to the soil conditions to be encountered or as to foundation materials.

19. AWARD IN CASE OF A TIE

In the event there are two or more responsive bidders, the decision to award will be based by the following criteria and in the following order:

- a. The incumbent will be awarded the bid over that of another bidder.
- b. In the case of a multi-item bid, if one bidder has been awarded other items from the same bid and the other bidder has not, the bidder with the multiple awards will be awarded the bid over that of another bidder.
- c. The bidder located in the State of Connecticut will be awarded the bid over that of another bidder.
- d. The winner of a coin toss will be awarded the bid over that of another bidder.

The above-referenced provisions do not apply to those situations in which more than one City-based business responsible bidder has submitted bids not more than ten (10) percent higher than the lowest bid and has agreed to accept the award of the bid at the amount of the lowest bid. Under such circumstances, the provisions of the Code of the City of Meriden, section 3-14, are controlling, as set forth under Section 8 of this 'Information to Bidders.'

20. ASSIGNMENT OF CONTRACT

No contract may be assigned without the written consent of the Purchasing Officer or designee.

21. PERMITS

The Contractor shall be responsible for obtaining any and all necessary permits required by the City of Meriden prior to the commencement of work. The Contractor may contact the City of Meriden Building Department for permit information at (203) 630-4091. For all other required permits, contact the City of Meriden Engineering Department at (203) 630-4018.

22. BID PRICE AND PAYMENT

The City of Meriden is exempt from the payment of the excise taxes imposed by the Federal government and the Sales and Use Tax of the State of Connecticut under Connecticut General Statutes; accordingly, such taxes shall not be included in the bid price.

The City of Meriden, unless stated otherwise in the bidding documents or Contract, will make payment to the Contractor not less than thirty (30) days following completion of services.

23. QUALITY

All materials, equipment, supplies, and services shall be subject to rigid inspection. If defective material, equipment, supplies, or services are discovered, the Contractor shall remove or make good such material, equipment, or supplies without extra compensation. It is expressly understood and agreed that any inspection by the City of Meriden will in no way lessen the responsibility of the Contractor or release Contractor from the obligation to perform and deliver to the City sound and satisfactory materials, equipment, supplies, or allow the cost to be deducted from any monies due it from the City of Meriden. All services will be performed in a workmanlike manner.

24. INSURANCE

The successful bidder shall be required to provide a Certificate of Insurance denoting general liability, automobile liability, workers compensation liability, and other coverage required by the City's Risk Manager.

25. CITY HALL CLOSING

If Meriden City Hall is closed due to inclement weather, or any other unforeseen event, bids will be due at the same time on the next business day that City Hall is open.

26. PAYMENT REQUISITIONS & CERTIFIED PAYROLL

Progress payment requisitions are due monthly on last day of the month for work completed during the contract period. Requisitions are to be sent to the Architect/Engineer and/or City of Meriden Department responsible for management/administration of the contracted work.

Certified Payroll for construction contracts that require State of Connecticut Prevailing Wage Determinations are required for each week of work by the Contractor and any or all the Contractor's Subcontractors and are due monthly with each requisition. One hard copy and one electronic copy shall be sent to the Architect/Engineer and the City of Meriden Purchasing Department. No progress payments will be issued to the Contractor without accompanying Certified Payroll.

For federally funded construction contracts with Davis Bacon Wage Determinations, Certified Payroll for all employees of the Contractor and any or all of the Contractor's Subcontractors are required to be submitted weekly to the Architect/Engineer and to the City of Meriden Purchasing Department. One hard copy and one electronic copy shall be sent to the Architect/Engineer and the City of Meriden Purchasing Department. Employees on the construction site will be interviewed by City of Meriden Staff and/or City of Meriden subcontracted Project Management/Clerk-of-the-Works/Owner's Representatives for Davis Bacon compliance. No progress payments will be issued to the Contractor without accompanying Certified Payroll.

27. CHRO – N/A

CITY OF MERIDEN, CONNECTICUT

B023-24 – IT Wiring at the Meriden Public Library

REQUEST FOR STATUS AS A MERIDEN-BASED BUSINESS

Bidders are specifically advised that the City of Meriden has adopted Section 3-14 of the Code of the City of Meriden which requires, but is not limited to, a local preference requiring, in part, that a “City-based business” shall mean a business with its principal place of business located within the boundaries of the City of Meriden. A business shall not be considered a “City-based business” unless evidence satisfactory to the Purchasing Department has been submitted with each bid by said business to establish that it has a bona fide principal place of business in the City of Meriden. Such evidence may include evidence of ownership or a long term lease of the real estate from which the principal place of business is operated, or payment of property taxes on the personal property of the business.

In determining the lowest responsible bidder, the Purchasing Department shall also consider the following:

Any City-based business bidder which has submitted a bid not more than ten (10%) percent higher than the low bid. Such City-based business shall agree to accept the award of the bid at the amount of the low bid. The acceptance shall be submitted in writing to the Purchasing Department no later than the same time of the bid opening on the next business day following the opening of the bid.

If more than one City based business bidder have submitted bids not more than ten (10%) percent higher than the low bid and have agreed to accept the award of the bid at the amount of the low bid, the lowest responsible bidder shall be that one which has submitted the lowest bid.

This section shall not apply in those instances where the bid requested involves a cooperative purchasing arrangement between the City of Meriden and other municipalities or the State of Connecticut.

The bidder may submit any additional information he/she desires that he/she feels establishes the company as a city based business, including but not limited to; evidence of ownership, a long term lease of the real estate from which the principal place of business is operated, or payment of property taxes on the personal property of the business.

1) Name of Bidder: _____

2) Meriden Office Address: _____

3) Minority owned: Yes _____ No _____

- 4) The undersigned hereby authorizes and requests any persons, firms, or corporations to furnish any information requested by the City of Meriden, in verification of the recitals comprising this Request for Status as a City Based Business.

Dated at: _____ this: _____ day of _____, 20 _____

Name of bidder: _____

By: _____

Title: _____

IF REQUESTING STATUS AS A MERIDEN-BASED BUSINESS, SUBMIT THIS FORM WITH YOUR PROPOSAL.

1. Minority owned business? _____ yes _____ no
2. Years organized. _____
3. Is your company a corporation _____ yes _____ no
If yes where incorporated? _____
4. How many years have you been engaged in business under your present firm name? _____
5. Former Firm Name (if any) _____
6. List total number of Personnel _____
7. Is any principal of your firm an employee or public official of the City of Meriden, or an immediate family member of an employee or public official of the City of Meriden? (Definition of immediate family includes: an individual's spouse, fiancé or fiancée; the parent, brother or sister of such individual or spouse; and the child of such individual or the spouse of such child.)
_____ yes _____ no
8. List Vehicles and Equipment that you will use to perform this work: (show age of vehicles and equipment, sizes, capacities, etc.)

9. List the work to be performed by Subcontractors and summarize the dollar value of each subcontract.

10. List the name and address of the more important contracts recently completed by you, starting the approximate gross cost for each, and the month and year completed:

11. General character of work performed by you _____

12. Have you ever failed to complete any contract awarded to you? If so, where and why?

13. Have you ever defaulted on a contract? If so where and why?

14. Have you ever filed bankruptcy: _____ Please explain: _____

15. Will you, upon request, furnish any information that may be required by the City of Meriden? _____
16. The undersigned hereby authorizes and request any person, firm or cooperation to furnish any information requested by the City of Meriden, in verification of the recitals comprising this Statement of Bidder's Qualifications.

Dated this _____ day of _____, 20____ year

 Name of Bidder

 Title

State of _____
 County of _____

_____ being duly sworn deposes and says that they are
 Name _____ of _____
 title _____ name of organization
 and that the answers to the forgoing question and all statement therein contained are true and correct

Subscribed and sworn to before me
 this _____ day of _____, 20____ year

 Notary Public signature

My commission expires _____

BID FORM

**B023-24
IT Wiring at the Meriden Public Library**

**Date of Opening: December 6, 2022
At 11:00 AM**

To: Adam B Tulin, MPA
Purchasing Officer
142 East Main Street, Room 210
Meriden, CT 06450

The undersigned _____, doing business in the City/Town of _____, in the State of _____, herewith, after reading thoroughly the Specifications and other Bid documents (including if any addendum or addenda) submit the following proposal:

Lump sum price:

_____ Dollars & Cents
Written Amount

Receipt of Addenda is acknowledged:

No: _____ Dated: _____

No: _____ Dated: _____

NAME OF BIDDER _____

ADDRESS _____

BY: _____
Print or type name Title

SIGNATURE _____ DATE _____

TELEPHONE _____ E-Mail _____

PLEASE NOTE: All spaces must be filled in with figures or words or your bid may be automatically rejected.



Opportunity * Guidance * Support



THIS IS A PUBLIC WORKS PROJECT

Covered by the

PREVAILING WAGE LAW

CT General Statutes Section 31-53

**If you have QUESTIONS regarding your wages
CALL (860) 263-6790**

Section 31-55 of the CT State Statutes requires every contractor or subcontractor performing work for the state to post in a prominent place the prevailing wages as determined by the Labor Commissioner.

Sec. 31-53b. Construction safety and health course. New miner training program. Proof of completion required for mechanics, laborers and workers on public works projects. Enforcement. Regulations. Exceptions. (a) Each contract for a public works project entered into on or after July 1, 2009, by the state or any of its agents, or by any political subdivision of the state or any of its agents, described in subsection (g) of section 31-53, shall contain a provision requiring that each contractor furnish proof with the weekly certified payroll form for the first week each employee begins work on such project that any person performing the work of a mechanic, laborer or worker pursuant to the classifications of labor under section 31-53 on such public works project, pursuant to such contract, has completed a course of at least ten hours in duration in construction safety and health approved by the federal Occupational Safety and Health Administration or, has completed a new miner training program approved by the Federal Mine Safety and Health Administration in accordance with 30 CFR 48 or, in the case of telecommunications employees, has completed at least ten hours of training in accordance with 29 CFR 1910.268.

(b) Any person required to complete a course or program under subsection (a) of this section who has not completed the course or program shall be subject to removal from the worksite if the person does not provide documentation of having completed such course or program by the fifteenth day after the date the person is found to be in noncompliance. The Labor Commissioner or said commissioner's designee shall enforce this section.

(c) Not later than January 1, 2009, the Labor Commissioner shall adopt regulations, in accordance with the provisions of chapter 54, to implement the provisions of subsections (a) and (b) of this section. Such regulations shall require that the ten-hour construction safety and health courses required under subsection (a) of this section be conducted in accordance with federal Occupational Safety and Health Administration Training Institute standards, or in accordance with Federal Mine Safety and Health Administration Standards or in accordance with 29 CFR 1910.268, as appropriate. The Labor Commissioner shall accept as sufficient proof of compliance with the provisions of subsection (a) or (b) of this section a student course completion card issued by the federal Occupational Safety and Health Administration Training Institute, or such other proof of compliance said commissioner deems appropriate, dated no earlier than five years before the commencement date of such public works project.

(d) This section shall not apply to employees of public service companies, as defined in section 16-1, or drivers of commercial motor vehicles driving the vehicle on the public works project and delivering or picking up cargo from public works projects provided they perform no labor relating to the project other than the loading and unloading of their cargo.

(P.A. 06-175, S. 1; P.A. 08-83, S. 1.)

History: P.A. 08-83 amended Subsec. (a) by making provisions applicable to public works project contracts entered into on or after July 1, 2009, replacing provision re total cost of work with reference to Sec. 31-53(g), requiring proof in certified payroll form that new mechanic, laborer or worker has completed a 10-hour or more construction safety course and adding provision re new miner training program, amended Subsec. (b) by substituting "person" for "employee" and adding "or program", amended Subsec. (c) by adding "or in accordance with Federal Mine Safety and Health Administration Standards" and setting new deadline of January 1, 2009, deleted former Subsec. (d) re "public building", added new Subsec. (d) re exemptions for public service company employees and delivery drivers who perform no labor other than delivery and made conforming and technical changes, effective January 1, 2009.

Informational Bulletin

THE 10-HOUR OSHA CONSTRUCTION SAFETY AND HEALTH COURSE

(applicable to public building contracts entered into *on or after July 1, 2007*, where the total cost of all work to be performed is at least \$100,000)

- (1) This requirement was created by Public Act No. 06-175, which is codified in Section 31-53b of the Connecticut General Statutes (pertaining to the prevailing wage statutes);
- (2) The course is required for public building construction contracts (projects funded in whole or in part by the state or any political subdivision of the state) entered into on or after July 1, 2007;
- (3) It is required of private employees (not state or municipal employees) and apprentices who perform manual labor for a general contractor or subcontractor on a public building project where the total cost of all work to be performed is at least \$100,000;
- (4) The ten-hour construction course pertains to the ten-hour Outreach Course conducted in accordance with federal OSHA Training Institute standards, and, for telecommunications workers, a ten-hour training course conducted in accordance with federal OSHA standard, 29 CFR 1910.268;
- (5) The internet website for the federal OSHA Training Institute is http://www.osha.gov/fso/ote/training/edcenters/fact_sheet.html;
- (6) The statutory language leaves it to the contractor and its employees to determine who pays for the cost of the ten-hour Outreach Course;
- (7) Within 30 days of receiving a contract award, a general contractor must furnish proof to the Labor Commissioner that all employees and apprentices performing manual labor on the project will have completed such a course;
- (8) Proof of completion may be demonstrated through either: (a) the presentation of a *bona fide* student course completion card issued by the federal OSHA Training Institute; *or* (2) the presentation of documentation provided to an employee by a trainer certified by the Institute pending the actual issuance of the completion card;
- (9) Any card with an issuance date more than 5 years prior to the commencement date of the construction project shall not constitute proof of compliance;

- (10) Each employer shall affix a copy of the construction safety course completion card to the certified payroll submitted to the contracting agency in accordance with Conn. Gen. Stat. § 31-53(f) on which such employee's name first appears;
- (11) Any employee found to be in non-compliance shall be subject to removal from the worksite if such employee does not provide satisfactory proof of course completion to the Labor Commissioner by the fifteenth day after the date the employee is determined to be in noncompliance;
- (12) Any such employee who is determined to be in noncompliance may continue to work on a public building construction project for a maximum of fourteen consecutive calendar days while bringing his or her status into compliance;
- (13) The Labor Commissioner may make complaint to the prosecuting authorities regarding any employer or agent of the employer, or officer or agent of the corporation who files a false certified payroll with respect to the status of an employee who is performing manual labor on a public building construction project;
- (14) The statute provides the minimum standards required for the completion of a safety course by manual laborers on public construction contracts; any contractor can exceed these minimum requirements; and
- (15) Regulations clarifying the statute are currently in the regulatory process, and shall be posted on the CTDOL website as soon as they are adopted in final form.
- (16) Any questions regarding this statute may be directed to the Wage and Workplace Standards Division of the Connecticut Labor Department via the internet website of <http://www.ctdol.state.ct.us/wgwkstnd/wgemenu.htm>; or by telephone at (860)263-6790.

THE ABOVE INFORMATION IS PROVIDED EXCLUSIVELY AS AN EDUCATIONAL RESOURCE, AND IS NOT INTENDED AS A SUBSTITUTE FOR LEGAL INTERPRETATIONS WHICH MAY ULTIMATELY ARISE CONCERNING THE CONSTRUCTION OF THE STATUTE OR THE REGULATIONS.

November 29, 2006

Notice
To All Mason Contractors and Interested Parties
Regarding Construction Pursuant to Section 31-53 of the
Connecticut General Statutes (Prevailing Wage)

The Connecticut Labor Department Wage and Workplace Standards Division is empowered to enforce the prevailing wage rates on projects covered by the above referenced statute.

Over the past few years the Division has withheld enforcement of the rate in effect for workers who operate a forklift on a prevailing wage rate project due to a potential jurisdictional dispute.

The rate listed in the schedules and in our Occupational Bulletin (see enclosed) has been as follows:

Forklift Operator:

- **Laborers (Group 4) Mason Tenders** - operates forklift solely to assist a mason to a maximum height of nine feet only.
- **Power Equipment Operator (Group 9)** - operates forklift to assist any trade and to assist a mason to a height over nine feet.

The U.S. Labor Department conducted a survey of rates in Connecticut but it has not been published and the rate in effect remains as outlined in the above Occupational Bulletin.

Since this is a classification matter and not one of jurisdiction, effective January 1, 2007 the Connecticut Labor Department will enforce the rate on each schedule in accordance with our statutory authority.

Your cooperation in filing appropriate and accurate certified payrolls is appreciated.

STATUTE 31-55a

- SPECIAL NOTICE -

To: All State and Political Subdivisions, Their Agents, and Contractors

Connecticut General Statute 31-55a - Annual adjustments to wage rates by contractors doing state work.

Each contractor that is awarded a contract on or after October 1, 2002, for (1) the construction of a state highway or bridge that falls under the provisions of section 31-54 of the general statutes, or (2) the construction, remodeling, refinishing, refurbishing, rehabilitation, alteration or repair of any public works project that falls under the provisions of section 31-53 of the general statutes shall contact the Labor Commissioner on or before July first of each year, for the duration of such contract, to ascertain the prevailing rate of wages on an hourly basis and the amount of payment or contributions paid or payable on behalf of each mechanic, laborer or worker employed upon the work contracted to be done, and shall make any necessary adjustments to such prevailing rate of wages and such payment or contributions paid or payable on behalf of each such employee, effective each July first.

- The prevailing wage rates applicable to any contract or subcontract awarded on or after October 1, 2002 are subject to annual adjustments each July 1st for the duration of any project which was originally advertised for bids on or after October 1, 2002.
- Each contractor affected by the above requirement shall pay the annual adjusted prevailing wage rate that is in effect each July 1st, as posted by the Department of Labor.
- It is the **contractor's** responsibility to obtain the annual adjusted prevailing wage rate increases directly from the Department of Labor's Web Site. The annual adjustments will be posted on the Department of Labor Web page: www.ctdol.state.ct.us. For those without internet access, please contact the division listed below.
- The Department of Labor will continue to issue the initial prevailing wage rate schedule to the Contracting Agency for the project. All subsequent annual adjustments will be posted on our Web Site for contractor access.

Any questions should be directed to the Contract Compliance Unit, Wage and Workplace Standards Division, Connecticut Department of Labor, 200 Folly Brook Blvd., Wethersfield, CT 06109 at (860)263-6790.

NOTICE

TO ALL CONTRACTING AGENCIES

Please be advised that Connecticut General Statutes Section 31-53, requires the contracting agency to certify to the Department of Labor, the total dollar amount of work to be done in connection with such public works project, regardless of whether such project consists of one or more contracts.

Please find the attached “Contracting Agency Certification Form” to be completed and returned to the Department of Labor, Wage and Workplace Standards Division, Public Contract Compliance Unit.

Inquiries can be directed to 860.263.6790.



CONNECTICUT DEPARTMENT OF LABOR
WAGE AND WORKPLACE STANDARDS DIVISION

Contracting Agency Certification Form

I, _____, acting in my official capacity as _____,
Authorized Representative Title

for _____, located at _____,
Contracting Agency Address

do hereby certify that the total dollar amount of work to be done in connection with

_____, located at _____,
Project name and number Address

shall be \$_____, which includes all work, regardless of whether such project
contains of one or more contracts.

Contractor Information

Name: _____

Address: _____

Authorized Representative: _____

Approximate Starting Date: _____

Approximate Completion Date: _____

Signature

Date

Return to:

Connecticut Department of Labor
Wage & Workplace Standards Division
200 Folly Brook Blvd.
Wethersfield, CT 06109

Rate Schedule Issued (Date): _____

CONNECTICUT DEPARTMENT OF LABOR
WAGE AND WORKPLACE STANDARDS DIVISION

CONTRACTORS WAGE CERTIFICATION FORM
Construction Manager at Risk/General Contractor/Prime Contractor

I, _____ of _____
Officer, Owner, Authorized Rep. Company Name

do hereby certify that the _____
Company Name

Street

City

and all of its subcontractors will pay all workers on the

Project Name and Number

Street and City

the wages as listed in the schedule of prevailing rates required for such project (a copy of which is attached hereto).

Signed

Subscribed and sworn to before me this _____ day of _____, _____.

Notary Public

Return to:

Connecticut Department of Labor
Wage & Workplace Standards Division
200 Folly Brook Blvd.
Wethersfield, CT 06109

Rate Schedule Issued (Date): _____

[New] In accordance with Section 31-53b(a) of the C.G.S. each contractor shall provide a copy of the OSHA 10 Hour Construction Safety and Health Card for each employee, to be attached to the first certified payroll on the project.

In accordance with Connecticut General Statutes, 31-53 Certified Payrolls with a statement of compliance shall be submitted monthly to the contracting agency.

PAYROLL CERTIFICATION FOR PUBLIC WORKS PROJECTS

Connecticut Department of Labor
Wage and Workplace Standards Division
200 Folly Brook Blvd.
Wethersfield, CT 06109

WEEKLY PAYROLL

CONTRACTOR NAME AND ADDRESS:											SUBCONTRACTOR NAME & ADDRESS				WORKER'S COMPENSATION INSURANCE CARRIER							
PAYROLL NUMBER	Week-Ending Date	PROJECT NAME & ADDRESS									POLICY #				EFFECTIVE DATE:		EXPIRATION DATE:					
PERSON/WORKER, ADDRESS and SECTION	APPR RATE %	MALE/FEMALE AND RACE*	WORK CLASSIFICATION	DAY AND DATE							Total ST Hours	BASE HOURLY RATE	TYPE OF FRINGE BENEFITS Per Hour 1 through 6 (see back)	GROSS PAY FOR ALL WORK PERFORMED THIS WEEK	TOTAL DEDUCTIONS				GROSS PAY FOR THIS PREVAILING RATE JOB	CHECK # AND NET PAY		
				S	M	T	W	TH	F	S	Total O/T Hours				FICA	FEDERAL WITH-HOLDING	STATE WITH-HOLDING	LIST OTHER				
			Trade License Type & Number - OSHA 10 Certification Number	HOURS WORKED EACH DAY								TOTAL FRINGE BENEFIT PLAN CASH										
												\$	1. \$									
												Base Rate	2. \$									
													3. \$									
													4. \$									
												\$	5. \$									
												Cash Fringe	6. \$									
												\$	1. \$									
												Base Rate	2. \$									
													3. \$									
													4. \$									
												\$	5. \$									
												Cash Fringe	6. \$									

12/9/2013 *IF REQUIRED

WWS-CPI

*SEE REVERSE SIDE

PAGE NUMBER ____ OF

***FRINGE BENEFITS EXPLANATION (P):**

Bona fide benefits paid to approved plans, funds or programs, except those required by Federal or State Law (unemployment tax, worker’s compensation, income taxes, etc.).

Please specify the type of benefits provided:

- 1) Medical or hospital care _____ 4) Disability _____
- 2) Pension or retirement _____ 5) Vacation, holiday _____
- 3) Life Insurance _____ 6) Other (please specify) _____

CERTIFIED STATEMENT OF COMPLIANCE

For the week ending date of _____,

I, _____ of _____, (hereafter known as Employer) in my capacity as _____ (title) do hereby certify and state:

Section A:

1. All persons employed on said project have been paid the full weekly wages earned by them during the week in accordance with Connecticut General Statutes, section 31-53, as amended. Further, I hereby certify and state the following:

- a) The records submitted are true and accurate;
- b) The rate of wages paid to each mechanic, laborer or workman and the amount of payment or contributions paid or payable on behalf of each such person to any employee welfare fund, as defined in Connecticut General Statutes, section 31-53 (h), are not less than the prevailing rate of wages and the amount of payment or contributions paid or payable on behalf of each such person to any employee welfare fund, as determined by the Labor Commissioner pursuant to subsection Connecticut General Statutes, section 31-53 (d), and said wages and benefits are not less than those which may also be required by contract;
- c) The Employer has complied with all of the provisions in Connecticut General Statutes, section 31-53 (and Section 31-54 if applicable for state highway construction);
- d) Each such person is covered by a worker’s compensation insurance policy for the duration of his employment which proof of coverage has been provided to the contracting agency;
- e) The Employer does not receive kickbacks, which means any money, fee, commission, credit, gift, gratuity, thing of value, or compensation of any kind which is provided directly or indirectly, to any prime contractor, prime contractor employee, subcontractor, or subcontractor employee for the purpose of improperly obtaining or rewarding favorable treatment in connection with a prime contract or in connection with a prime contractor in connection with a subcontractor relating to a prime contractor; and
- f) The Employer is aware that filing a certified payroll which he knows to be false is a class D felony for which the employer may be fined up to five thousand dollars, imprisoned for up to five years or both.

2. OSHA~The employer shall affix a copy of the construction safety course, program or training completion document to the certified payroll required to be submitted to the contracting agency for this project on which such persons name first appears.

 (Signature) (Title) Submitted on (Date)

[New] In accordance with Section 31-53b(a) of the C.G.S. each contractor shall provide a copy of the OSHA 10 Hour Construction Safety and Health Card for each employee, to be attached to the first certified payroll on the project.

PAYROLL CERTIFICATION FOR PUBLIC WORKS PROJECTS										Connecticut Department of Labor Wage and Workplace Standards Division 200 Folly Brook Blvd. Wethersfield, CT 06109									
In accordance with Connecticut General Statutes, 31-53 Certified Payrolls with a statement of compliance shall be submitted monthly to the contracting agency.										WEEKLY PAYROLL									
CONTRACTOR NAME AND ADDRESS: Landon Corporation, 15 Connecticut Avenue, Northford, CT 06472										SUBCONTRACTOR NAME & ADDRESS XYZ Corporation 2 Main Street Yantic, CT 06389				WORKER'S COMPENSATION INSURANCE CARRIER Travelers Insurance Company POLICY # #BAC8888928 EFFECTIVE DATE: 1/1/09 EXPIRATION DATE: 12/31/09					
PAYROLL NUMBER	Week-Ending Date	PROJECT NAME & ADDRESS DOT 105-296, Route 82								Total ST Hours	BASE HOURLY RATE	TYPE OF FRINGE BENEFITS Per Hour 1 through 6 (see back)	GROSS PAY FOR ALL WORK PERFORMED THIS WEEK	TOTAL DEDUCTIONS				GROSS PAY FOR THIS PREVAILING RATE JOB	CHECK # AND NET PAY
														FEDERAL	STATE	LIST OTHER	FICA		
PERSON/WORKER, ADDRESS and SECTION	APPR RATE %	MALE/FEMALE AND RACE*	WORK CLASSIFICATION	DAY AND DATE							Total O/T Hours	TOTAL FRINGE BENEFIT PLAN CASH	GROSS PAY FOR ALL WORK PERFORMED THIS WEEK	FICA	WITH-HOLDING	WITH-HOLDING	LIST OTHER	GROSS PAY FOR THIS PREVAILING RATE JOB	CHECK # AND NET PAY
			S	M	T	W	TH	F	S	HOURS WORKED EACH DAY									
Robert Craft 81 Maple Street Willimantic, CT 06226		M/C	Electrical Lineman E-1 1234567 Owner OSHA 123456		8	8	8	8	8										
										S-TIME 40	\$ 30.75 Base Rate	\$1,582.80					P-xxxx	\$1,582.80	#123 \$ xxx.xx
										O-TIME	\$ 8.82 Cash Fringe								
Ronald Jones 212 Elm Street Norwich, CT 06360	65%	M/B	Electrical Apprentice OSHA 234567		8	8	8	8	8										
										S-TIME 40	\$ 19.99 Base Rate	\$1,464.80	xx.xx	xxx.xx	xx.xx	G-xxx	\$1,464.80	#124 \$xxx.xx	
										O-TIME	\$ 16.63 Cash Fringe								
Franklin T. Smith 234 Washington Rd. New London, CT 06320 SECTION B		M/H	Project Manager			8													
										S-TIME 8	\$ Base Rate	\$1,500.00	xx.xx	xx.xx	xx.xx	M-xx.x		#125 xxx.xx	
										O-TIME	\$ Cash Fringe								
										S-TIME	\$ Base Rate								
										O-TIME	\$ Cash Fringe								

7/13/2009 *IF REQUIRED
WWS-CP1

*SEE REVERSE SIDE

PAGE NUMBER 1 OF 2

OSHA 10 ~ATTACH CARD TO 1ST CERTIFIED PAYROLL

***FRINGE BENEFITS EXPLANATION (P):**

Bona fide benefits paid to approved plans, funds or programs, except those required by Federal or State Law (unemployment tax, worker's compensation, income taxes, etc.).

Please specify the type of benefits provided:

- 1) Medical or hospital care Blue Cross 4) Disability _____
- 2) Pension or retirement _____ 5) Vacation, holiday _____
- 3) Life Insurance Utopia 6) Other (please specify) _____

CERTIFIED STATEMENT OF COMPLIANCE

For the week ending date of 9/26/09,

I, Robert Craft of XYZ Corporation, (hereafter known as

Employer) in my capacity as Owner (title) do hereby certify and state:

Section A:

1. All persons employed on said project have been paid the full weekly wages earned by them during the week in accordance with Connecticut General Statutes, section 31-53, as amended. Further, I hereby certify and state the following:

- a) The records submitted are true and accurate;
- b) The rate of wages paid to each mechanic, laborer or workman and the amount of payment or contributions paid or payable on behalf of each such employee to any employee welfare fund, as defined in Connecticut General Statutes, section 31-53 (h), are not less than the prevailing rate of wages and the amount of payment or contributions paid or payable on behalf of each such employee to any employee welfare fund, as determined by the Labor Commissioner pursuant to subsection Connecticut General Statutes, section 31-53 (d), and said wages and benefits are not less than those which may also be required by contract;
- c) The Employer has complied with all of the provisions in Connecticut General Statutes, section 31-53 (and Section 31-54 if applicable for state highway construction);
- d) Each such employee of the Employer is covered by a worker's compensation insurance policy for the duration of his employment which proof of coverage has been provided to the contracting agency;
- e) The Employer does not receive kickbacks, which means any money, fee, commission, credit, gift, gratuity, thing of value, or compensation of any kind which is provided directly or indirectly, to any prime contractor, prime contractor employee, subcontractor, or subcontractor employee for the purpose of improperly obtaining or rewarding favorable treatment in connection with a prime contract or in connection with a prime contractor in connection with a subcontractor relating to a prime contractor; and
- f) The Employer is aware that filing a certified payroll which he knows to be false is a class D felony for which the employer may be fined up to five thousand dollars, imprisoned for up to five years or both.

2. OSHA~The employer shall affix a copy of the construction safety course, program or training completion document to the certified payroll required to be submitted to the contracting agency for this project on which such employee's name first appears.

Robert Craft owner 10/2/09
 (Signature) (Title) Submitted on (Date)

Section B: Applies to CONNDOT Projects ONLY

That pursuant to CONNDOT contract requirements for reporting purposes only, all employees listed under Section B who performed work on this project are not covered under the prevailing wage requirements defined in Connecticut General Statutes Section 31-53.

Robert Craft owner 10/2/09
 (Signature) (Title) Submitted on (Date)

Note: CTDOL will assume all hours worked were performed under Section A unless clearly delineated as Section B WWS-CP1 as such. Should an employee perform work under both Section A and Section B, the hours worked and wages paid must be segregated for reporting purposes.

*****THIS IS A PUBLIC DOCUMENT***
DO NOT INCLUDE SOCIAL SECURITY NUMBERS**

Information Bulletin ***Occupational Classifications***

The Connecticut Department of Labor has the responsibility to properly determine "job classification" on prevailing wage projects covered under C.G.S. Section 31-53(d).

Note: This information is intended to provide a sample of some occupational classifications for guidance purposes only. It is not an all-inclusive list of each occupation's duties. This list is being provided only to highlight some areas where a contractor may be unclear regarding the proper classification. If unsure, the employer should seek guidelines for CTDOL.

Below are additional clarifications of specific job duties performed for certain classifications:

- **ASBESTOS WORKERS**

Applies all insulating materials, protective coverings, coatings and finishes to all types of mechanical systems.

- **ASBESTOS INSULATOR**

Handle, install apply, fabricate, distribute, prepare, alter, repair, dismantle, heat and frost insulation, including penetration and fire stopping work on all penetration fire stop systems.

- **BOILERMAKERS**

Erects hydro plants, incomplete vessels, steel stacks, storage tanks for water, fuel, etc. Builds incomplete boilers, repairs heat exchanges and steam generators.

- **BRICKLAYERS, CEMENT MASONS, CEMENT FINISHERS, MARBLE MASONS, PLASTERERS, STONE MASONS, PLASTERERS. STONE MASONS, TERRAZZO WORKERS, TILE SETTERS**

Lays building materials such as brick, structural tile and concrete cinder, glass, gypsum, terra cotta block. Cuts, tools and sets marble, sets stone, finishes concrete, applies decorative steel, aluminum and plastic tile, applies cements, sand, pigment and marble chips to floors, stairways, etc.

- **CARPENTERS, MILLWRIGHTS. PILEDRIVERMEN. LATHERS. RESILEINT FLOOR LAYERS, DOCK BUILDERS, DIKERS, DIVER TENDERS**

Constructs, erects, installs and repairs structures and fixtures of wood, plywood and wallboard. Installs, assembles, dismantles, moves industrial machinery. Drives piling into ground to provide foundations for structures such as buildings and bridges, retaining walls for earth embankments, such as cofferdams. Fastens wooden, metal or rockboard lath to walls, ceilings and partitions of buildings, acoustical tile layer, concrete form builder. Applies firestopping materials on fire resistive joint systems only. Installation of curtain/window walls only where attached to wood or metal studs. Installation of insulated material of all types whether blown, nailed or attached in other ways to walls, ceilings and floors of buildings. Assembly and installation of modular furniture/furniture systems. Free-standing furniture is not covered. This includes free standing: student chairs, study top desks, book box desks, computer furniture, dictionary stand, atlas stand, wood shelving, two-position information access station, file cabinets, storage cabinets, tables, etc.

- **LABORER, CLEANING**

- The clean up of any construction debris and the general (heavy/light) cleaning, including sweeping, wash down, mopping, wiping of the construction facility and its furniture, washing, polishing, and dusting.

- **DELIVERY PERSONNEL**

- If delivery of supplies/building materials is to one common point and stockpiled there, prevailing wages are not required. If the delivery personnel are involved in the distribution of the material to multiple locations within the construction site then they would have to be paid prevailing wages for the type of work performed: laborer, equipment operator, electrician, ironworker, plumber, etc.

- An example of this would be where delivery of drywall is made to a building and the delivery personnel distribute the drywall from one "stockpile" location to further sub-locations on each floor. Distribution of material around a construction site is the job of a laborer or tradesman, and not a delivery personnel.

- **ELECTRICIANS**

Install, erect, maintenance, alteration or repair of any wire, cable, conduit, etc., which generates, transforms, transmits or uses electrical energy for light, heat, power or other purposes, including the Installation or maintenance of telecommunication, LAN wiring or computer equipment, and low voltage wiring. ****License required per Connecticut General Statutes: E-1,2 L-5,6 C-5,6 T-1,2 L-1,2 V-1,2,7,8,9.***

- **ELEVATOR CONSTRUCTORS**

Install, erect, maintenance and repair of all types of elevators, escalators, dumb waiters and moving walks. **License required by Connecticut General Statutes: R-1,2,5,6.*

- **FORK LIFT OPERATOR**

Laborers Group 4) Mason Tenders - operates forklift solely to assist a mason to a maximum height of nine (9) feet only.

Power Equipment Operator Group 9 - operates forklift to assist any trade, and to assist a mason to a height over nine (9) feet.

- **GLAZIERS**

Glazing wood and metal sash, doors, partitions, and 2 story aluminum storefronts. Installs glass windows, skylights, store fronts and display cases or surfaces such as building fronts, interior walls, ceilings and table tops and metal store fronts. Installation of aluminum window walls and curtain walls is the "joint" work of glaziers and ironworkers, which require equal composite workforce.

- **IRONWORKERS**

Erection, installation and placement of structural steel, precast concrete, miscellaneous iron, ornamental iron, metal curtain wall, rigging and reinforcing steel. Handling, sorting, and installation of reinforcing steel (rebar). Metal bridge rail (traffic), metal bridge handrail, and decorative security fence installation. Installation of aluminum window walls and curtain walls is the "joint" work of glaziers and ironworkers which require equal composite workforce.

- **INSULATOR**

- Installing fire stopping systems/materials for "Penetration Firestop Systems": transit to cables, electrical conduits, insulated pipes, sprinkler pipe penetrations, ductwork behind radiation, electrical cable trays, fire rated pipe penetrations, natural polypropylene, HVAC ducts, plumbing bare metal, telephone and communication wires, and boiler room ceilings.

- **LABORERS**

Acetylene burners, asphalt rakers, chain saw operators, concrete and power buggy operator, concrete saw operator, fence and guard rail erector (except metal bridge rail (traffic), decorative security fence (non-metal)).

installation.), hand operated concrete vibrator operator, mason tenders, pipelayers (installation of storm drainage or sewage lines on the street only), pneumatic drill operator, pneumatic gas and electric drill operator, powermen and wagon drill operator, air track operator, block paver, curb setters, blasters, concrete spreaders.

- **PAINTERS**

Maintenance, preparation, cleaning, blasting (water and sand, etc.), painting or application of any protective coatings of every description on all bridges and appurtenances of highways, roadways, and railroads. Painting, decorating, hardwood finishing, paper hanging, sign writing, scenic art work and drywall hhg for any and all types of building and residential work.

- **LEAD PAINT REMOVAL**

- Painter's Rate

1. Removal of lead paint from bridges.
2. Removal of lead paint as preparation of any surface to be repainted.
3. Where removal is on a Demolition project prior to reconstruction.

- Laborer's Rate

1. Removal of lead paint from any surface NOT to be repainted.
2. Where removal is on a *TOTAL* Demolition project only.

- **PLUMBERS AND PIPEFITTERS**

Installation, repair, replacement, alteration or maintenance of all plumbing, heating, cooling and piping. ****License required per Connecticut General Statutes: P-1,2,6,7,8,9 J-1,2,3,4 SP-1,2 S-1,2,3,4,5,6,7,8 B-1,2,3,4 D-1,2,3,4.***

- **POWER EQUIPMENT OPERATORS**

Operates several types of power construction equipment such as compressors, pumps, hoists, derricks, cranes, shovels, tractors, scrapers or motor graders, etc. Repairs and maintains equipment. ****License required, crane operators only, per Connecticut General Statutes.***

- **ROOFERS**

Covers roofs with composition shingles or sheets, wood shingles, slate or asphalt and gravel to waterproof roofs, including preparation of surface. (demolition or removal of any type of roofing and or clean-up of any and all areas where a roof is to be relaid.)

- **SHEETMETAL WORKERS**

Fabricate, assembles, installs and repairs sheetmetal products and equipment in such areas as ventilation, air-conditioning, warm air heating, restaurant equipment, architectural sheet metal work, sheetmetal roofing, and aluminum gutters. Fabrication, handling, assembling, erecting, altering, repairing, etc. of coated metal material panels and composite metal material panels when used on building exteriors and interiors as soffits, fascia, louvers, partitions, canopies, cornice, column covers, awnings, beam covers, cladding, sun shades, lighting troughs, spires, ornamental roofing, metal ceilings, mansards, copings, ornamental and ventilation hoods, vertical and horizontal siding panels, trim, etc. The sheet metal classification also applies to the vast variety of coated metal material panels and composite metal material panels that have evolved over the years as an alternative to conventional ferrous and non-ferrous metals like steel, iron, tin, copper, brass, bronze, aluminum, etc. Fabrication, handling, assembling, erecting, altering, repairing, etc. of architectural metal roof, standing seam roof, composite metal roof, metal and composite bathroom/toilet partitions, aluminum gutters, metal and composite lockers and shelving, kitchen equipment, and walk-in coolers. To include testing and air –balancing ancillary to installation and construction.

- **SPRINKLER FITTERS**

Installation, alteration, maintenance and repair of fire protection sprinkler systems.

****License required per Connecticut General Statutes: F-1,2,3,4.***

- **TILE MARBLE AND TERRAZZO FINISHERS**

Assists and tends the tile setter, marble mason and terrazzo worker in the performance of their duties.

- **TRUCK DRIVERS**

~How to pay truck drivers delivering asphalt is under REVISION~

Truck Drivers are required to be paid prevailing wage for time spent "working" directly on the site. These drivers remain covered by the prevailing wage for any time spent transporting between the actual construction location and facilities (such as fabrication, plants, mobile factories, batch plant, borrow pits, job headquarters, tool yards, etc.) dedicated exclusively, or nearly so, to performance of the contract or project, which are so located in proximity to the actual construction location that it is reasonable to include them. ****License required, drivers only, per Connecticut General Statutes.***

For example:

- Material men and deliverymen are not covered under prevailing wage as long as they are not directly involved in the construction process. If, they unload the material, they would then be covered by prevailing wage for the classification they are performing work in: laborer, equipment operator, etc.
- Hauling material off site is not covered provided they are not dumping it at a location outlined above.
- Driving a truck on site and moving equipment or materials on site would be considered covered work, as this is part of the construction process.

➤ *Any questions regarding the proper classification should be directed to:*
Public Contract Compliance Unit
Wage and Workplace Standards Division
Connecticut Department of Labor
200 Folly Brook Blvd, Wethersfield, CT 06109
(860) 263-6790.

**Connecticut Department of Labor
Wage and Workplace Standards Division
FOOTNOTES**

⇒ Please Note: If the “Benefits” listed on the schedule for the following occupations includes a letter(s) (+ a or + a+b for instance), refer to the information below.

Benefits to be paid at the appropriate prevailing wage rate for the listed occupation.

If the “Benefits” section for the occupation lists only a dollar amount, disregard the information below.

Bricklayers, Cement Masons, Cement Finishers, Concrete Finishers, Stone Masons
(Building Construction) and
(Residential- Hartford, Middlesex, New Haven, New London and Tolland Counties)

- a. Paid Holiday: Employees shall receive 4 hours for Christmas Eve holiday provided the employee works the regularly scheduled day before and after the holiday. Employers may schedule work on Christmas Eve and employees shall receive pay for actual hours worked in addition to holiday pay.

Elevator Constructors: Mechanics

- a. Paid Holidays: New Year’s Day, Memorial Day, Independence Day, Labor Day, Veterans’ Day, Thanksgiving Day, Christmas Day, plus the Friday after Thanksgiving.
- b. Vacation: Employer contributes 8% of basic hourly rate for 5 years or more of service or 6% of basic hourly rate for 6 months to 5 years of service as vacation pay credit.

Glaziers

- a. Paid Holidays: Labor Day and Christmas Day.

Power Equipment Operators
(Heavy and Highway Construction & Building Construction)

- a. Paid Holidays: New Year’s Day, Good Friday, Memorial day, Independence Day, Labor Day, Thanksgiving Day and Christmas Day, provided the employee works 3 days during the week in which the holiday falls, if scheduled, and if scheduled, the working day before and the working day after the holiday. Holidays falling on Saturday may be observed on Saturday, or if the employer so elects, on the preceding Friday.

Ironworkers

- a. Paid Holiday: Labor Day provided employee has been on the payroll for the 5 consecutive work days prior to Labor Day.

Laborers (Tunnel Construction)

- a. Paid Holidays: New Year's Day, Memorial Day, Independence Day, Labor Day, Thanksgiving Day and Christmas Day. No employee shall be eligible for holiday pay when he fails, without cause, to work the regular work day preceding the holiday or the regular work day following the holiday.

Roofers

- a. Paid Holidays: July 4th, Labor Day, and Christmas Day provided the employee is employed 15 days prior to the holiday.

Sprinkler Fitters

- a. Paid Holidays: Memorial Day, July 4th, Labor Day, Thanksgiving Day and Christmas Day, provided the employee has been in the employment of a contractor 20 working days prior to any such paid holiday.

Truck Drivers

(Heavy and Highway Construction & Building Construction)

- a. Paid Holidays: New Year's Day, Memorial Day, Independence Day, Labor Day, Thanksgiving Day, Christmas day, and Good Friday, provided the employee has at least 31 calendar days of service and works the last scheduled day before and the first scheduled day after the holiday, unless excused.

Important Information:

Welders: Rate for craft to which welding is incidental.

*Note: Hazardous waste removal work receives additional \$1.25 per hour for truck drivers.

**Note: Hazardous waste premium \$3.00 per hour over classified rate

Crane with 150 ft. boom (including jib) - \$1.50 extra

Crane with 200 ft. boom (including jib) - \$2.50 extra

Crane with 250 ft. boom (including jib) - \$5.00 extra

Crane with 300 ft. boom (including jib) - \$7.00 extra

Crane with 400 ft. boom (including jib) - \$10.00 extra

All classifications that indicate a percentage of the fringe benefits must be calculated at the percentage rate times the "base hourly rate".

Apprentices duly registered under the Commissioner of Labor's regulations on "Work Training Standards for Apprenticeship and Training Programs" Section 31-51-d-1 to 12, are allowed to be paid the appropriate percentage of the prevailing journeymen hourly base and the full fringe benefit rate, providing the work site ratio shall not be less than one full-time journeyman instructing and supervising the work of each apprentice in a specific trade.

The Prevailing wage rates applicable to this project are subject to annual adjustments each July 1st for the duration of the project.

Each contractor shall pay the annual adjusted prevailing wage rate that is in effect each July 1st, as posted by the Department of Labor.

It is the contractor's responsibility to obtain the annual adjusted prevailing wage rate increases directly from the Department of Labor's website.

The annual adjustments will be posted on the Department of Labor's Web page: www.ct.gov/dol. For those without internet access, please contact the division listed below.

The Department of Labor will continue to issue the initial prevailing wage rate schedule to the Contracting Agency for the project.

All subsequent annual adjustments will be posted on our Web Site for contractor access.

Contracting Agencies are under no obligation pursuant to State labor law to pay any increase due to the annual adjustment provision.

Effective October 1, 2005 - Public Act 05-50: any person performing the work of any mechanic, laborer, or worker shall be paid prevailing wage

All Person who perform work ON SITE must be paid prevailing wage for the appropriate mechanic, laborer, or worker classification.

All certified payrolls must list the hours worked and wages paid to All Persons who perform work ON SITE regardless of their ownership i.e.: (Owners, Corporate Officers, LLC Members, Independent Contractors, et. al)

Reporting and payment of wages is required regardless of any contractual relationship alleged to exist between the contractor and such person.

~~Unlisted classifications needed for work not included within the scope of the classifications listed may be added after award only as provided in the labor standards contract clause (29 CFR 5.5 (a) (1) (ii)).

Please direct any questions which you may have pertaining to classification of work and payment of prevailing wages to the Wage and Workplace Standards Division, telephone (860)263-6790.

Minimum Rates and Classifications for Building Construction

ID#: 21-26390

**Connecticut Department of Labor
Wage and Workplace Standards Division**

By virtue of the authority vested in the Labor Commissioner under provisions of Section 31-53 of the General Statutes of Connecticut, as amended, the following are declared to be the prevailing rates and welfare payments and will apply only where the contract is advertised for bid within 20 days of the date on which the rates are established. Any contractor or subcontractor not obligated by agreement to pay to the welfare and pension fund shall pay this amount to each employee as part of his/her hourly wages.

Project Number: B022-01

Project Town: Meriden

State#: B022-01

FAP#: Meriden

Project: Meriden Public Library Renovation (Meriden)

CLASSIFICATION	Hourly Rate	Benefits
1b) Asbestos/Toxic Waste Removal Laborers: Asbestos removal and encapsulation (except its removal from mechanical systems which are not to be scrapped), toxic waste removers, blasters.**See Laborers Group 7**		
1c) Asbestos Worker/Heat and Frost Insulator	43.72	30.99
2) Boilermaker	38.34	26.01
3a) Bricklayer, Cement Mason, Concrete Finisher (including caulking), Stone Masons	36.18	34.59 + a
3b) Tile Setter	34.9	25.87
3c) Terrazzo Mechanics and Marble Setters	31.69	22.35
3d) Tile, Marble & Terrazzo Finishers	26.7	21.75
3e) Plasterer	33.48	32.06
-----LABORERS-----		
4) Group 1: Laborers (common or general), acetylene burners, concrete specialists, wrecking laborers, fire watchers.	31.5	23.25
4a) Group 2: Mortar mixers, plaster tender, power buggy operators, powdermen, fireproofers/mixer/nozzleman (Person running mixer and spraying fireproof only).	31.75	23.25

Project: Meriden Public Library Renovation (Meriden)

4b) Group 3: Jackhammer operators/pavement breaker, mason tender (brick), mason tender (cement/concrete), forklift operators and forklift operators (masonry).	32.0	23.25
4c) **Group 4: Pipelayers (Installation of water, storm drainage or sewage lines outside of the building line with P6, P7 license) (the pipelayer rate shall apply only to one or two employees of the total crew who primary task is to actually perform the mating of pipe sections) P6 and P7 rate is \$26.80.	32.5	23.25
4d) Group 5: Air track operator, sand blaster and hydraulic drills.	32.25	23.25
4e) Group 6: Blasters, nuclear and toxic waste removal.	34.5	23.25
4f) Group 7: Asbestos/lead removal and encapsulation (except it's removal from mechanical systems which are not to be scrapped).	32.5	23.25
4g) Group 8: Bottom men on open air caisson, cylindrical work and boring crew.	29.78	23.25
4h) Group 9: Top men on open air caisson, cylindrical work and boring crew.	29.24	23.25
4i) Group 10: Traffic Control Signalman	18.0	23.25
5) Carpenter, Acoustical Ceiling Installation, Soft Floor/Carpet Laying, Metal Stud Installation, Form Work and Scaffold Building, Drywall Hanging, Modular-Furniture Systems Installers, Lathers, Piledrivers, Resilient Floor Layers.	35.57	25.65
5a) Millwrights	35.64	26.49
6) Electrical Worker (including low voltage wiring) (Trade License required: E1,2 L-5,6 C-5,6 T-1,2 L-1,2 V-1,2,7,8,9)	39.6	31.21+3% of gross wage
7a) Elevator Mechanic (Trade License required: R-1,2,5,6)	56.96	35.825+a+b
-----LINE CONSTRUCTION-----		
Groundman	26.5	6.5% + 9.00
Linemen/Cable Splicer	48.19	6.5% + 22.00
8) Glazier (Trade License required: FG-1,2)	39.98	22.90 + a

As of: September 8, 2021

9) Ironworker, Ornamental, Reinforcing, Structural, and Precast Concrete Erection	38.17	38.02 + a
-----OPERATORS-----		
Group 1: Crane handling or erecting structural steel or stone, hoisting engineer 2 drums or over, front end loader (7 cubic yards or over), work boat 26 ft. and over and Tunnel Boring Machines. (Trade License Required)	43.88	25.80 + a
Group 2: Cranes (100 ton rate capacity and over); Excavator over 2 cubic yards; Piledriver (\$3.00 premium when operator controls hammer); Bauer Drill/Caisson. (Trade License Required)	43.53	25.80 + a
Group 3: Excavator; Backhoe/Excavator under 2 cubic yards; Cranes (under 100 ton rated capacity), Grader/Blade; Master Mechanic; Hoisting Engineer (all types of equipment where a drum and cable are used to hoist or drag material regardless of motive power of operation), Rubber Tire Excavator (Drott-1085 or similar); Grader Operator; Bulldozer Fine Grade. (slopes, shaping, laser or GPS, etc.). (Trade License Required)	42.72	25.80 + a
Group 4: Trenching Machines; Lighter Derrick; Concrete Finishing Machine; CMI Machine or Similar; Koehring Loader (Skooper).	42.3	25.80 + a
Group 5: Specialty Railroad Equipment; Asphalt Paver; Asphalt Reclaiming Machine; Line Grinder; Concrete Pumps; Drills with Self Contained Power Units; Boring Machine; Post Hole Digger; Auger; Pounder; Well Digger; Milling Machine (over 24	41.65	25.80 + a
Group 5 continued: Side Boom; Combination Hoe and Loader; Directional Driller; Pile Testing Machine.	41.65	25.80 + a
Group 6: Front End Loader (3 up to 7 cubic yards); Bulldozer (rough grade dozer).	41.31	25.80 + a
Group 7: Asphalt roller, concrete saws and cutters (ride on types), vermeer concrete cutter, Stump Grinder; Scraper; Snooper; Skidder; Milling Machine (24	40.94	25.80 + a
Group 8: Mechanic, grease truck operator, hydroblaster; barrier mover; power stone spreader; welding; work boat under 26 ft.; transfer machine.	40.51	25.80 + a
Group 9: Front end loader (under 3 cubic yards), skid steer loader regardless of attachments, (Bobcat or Similar): forklift, power chipper; landscape equipment (including Hydroseeder).	40.04	25.80 + a
Group 10: Vibratory hammer; ice machine; diesel and air, hammer, etc.	37.81	25.80 + a
Group 11: Conveyor, earth roller, power pavement breaker (whiphammer), robot demolition equipment.	37.81	25.80 + a

Project: Meriden Public Library Renovation (Meriden)

Group 12: Wellpoint operator.	37.74	25.80 + a
Group 13: Compressor battery operator.	37.11	25.80 + a
Group 14: Elevator operator; tow motor operator (solid tire no rough terrain).	35.87	25.80 + a
Group 15: Generator Operator; Compressor Operator; Pump Operator; Welding Machine Operator; Heater Operator.	35.43	25.80 + a
Group 16: Maintenance Engineer/Oiler.	34.72	25.80 + a
Group 17: Portable asphalt plant operator; portable crusher plant operator; portable concrete plant operator.	39.42	25.80 + a
Group 18: Power safety boat; vacuum truck; zim mixer; sweeper; (Minimum for any job requiring a CDL license).	36.77	25.80 + a
-----PAINTERS (Including Drywall Finishing)-----		
10a) Brush and Roller	36.42	22.90
10b) Taping Only/Drywall Finishing	37.17	22.90
10c) Paperhanger and Red Label	36.92	22.90
10e) Blast and Spray	39.42	22.90
11) Plumber (excluding HVAC pipe installation) (Trade License required: P-1,2,6,7,8,9 J-1,2,3,4 SP-1,2)	45.83	33.50
12) Well Digger, Pile Testing Machine	37.26	24.05 + a
13) Roofer (composition)	38.5	21.50
14) Roofer (slate & tile)	39.0	21.50
15) Sheetmetal Worker (Trade License required for HVAC and Ductwork: SM-1,SM-2,SM-3,SM-4,SM-5,SM-6)	40.08	41.26
16) Pipefitter (Including HVAC work) (Trade License required: S-1,2,3,4,5,6,7,8 B-1,2,3,4 D-1,2,3,4, G-1, G-2, G-8 & G-9)	45.83	33.50

As of: September 8, 2021

-----TRUCK DRIVERS-----

17a) 2 Axle	30.16	27.16 + a
17b) 3 Axle, 2 Axle Ready Mix	30.27	27.16 + a
17c) 3 Axle Ready Mix	30.33	27.16 + a
17d) 4 Axle, Heavy Duty Trailer up to 40 tons	30.39	27.16 + a
17e) 4 Axle Ready Mix	30.44	27.16 + a
17f) Heavy Duty Trailer (40 Tons and Over)	30.66	27.16 + a
17g) Specialized Earth Moving Equipment (Other Than Conventional Type on-the-Road Trucks and Semi-Trailers, Including Euclids)	30.44	27.16 + a
18) Sprinkler Fitter (Trade License required: F-1,2,3,4)	47.55	26.60 + a
19) Theatrical Stage Journeyman	25.76	7.34

Project: Meriden Public Library Renovation (Meriden)

Welders: Rate for craft to which welding is incidental.

**Note: Hazardous waste removal work receives additional \$1.25 per hour for truck drivers.*

***Note: Hazardous waste premium \$3.00 per hour over classified rate*

ALL Cranes: When crane operator is operating equipment that requires a fully licensed crane operator to operate he receives an extra \$4.00 premium in addition to the hourly wage rate and benefit contributions:

- 1) Crane handling or erecting structural steel or stone; hoisting engineer (2 drums or over)***
- 2) Cranes (100 ton rate capacity and over) Bauer Drill/Caisson***
- 3) Cranes (under 100 ton rated capacity)***

Crane with 150 ft. boom (including jib) - \$1.50 extra

Crane with 200 ft. boom (including jib) - \$2.50 extra

Crane with 250 ft. boom (including jib) - \$5.00 extra

Crane with 300 ft. boom (including jib) - \$7.00 extra

Crane with 400 ft. boom (including jib) - \$10.00 extra

All classifications that indicate a percentage of the fringe benefits must be calculated at the percentage rate times the "base hourly rate".

Apprentices duly registered under the Commissioner of Labor's regulations on "Work Training Standards for Apprenticeship and Training Programs" Section 31-51-d-1 to 12, are allowed to be paid the appropriate percentage of the prevailing journeymen hourly base and the full fringe benefit rate, providing the work site ratio shall not be less than one full-time journeyperson instructing and supervising the work of each apprentice in a specific trade.

The Prevailing wage rates applicable to this project are subject to annual adjustments each July 1st for the duration of the project.

Each contractor shall pay the annual adjusted prevailing wage rate that is in effect each July 1st, as posted by the Department of Labor.

It is the contractor's responsibility to obtain the annual adjusted prevailing wage rate increases directly from the Department of Labor's website.

The annual adjustments will be posted on the Department of Labor's Web page: www.ct.gov/dol. For those without internet access, please contact the division listed below.

The Department of Labor will continue to issue the initial prevailing wage rate schedule to the Contracting Agency for the project.

All subsequent annual adjustments will be posted on our Web Site for contractor access.

Contracting Agencies are under no obligation pursuant to State labor law to pay any increase due to the annual adjustment provision.

Effective October 1, 2005 - Public Act 05-50: any person performing the work of any mechanic, laborer, or worker shall be paid prevailing wage

All Person who perform work ON SITE must be paid prevailing wage for the appropriate mechanic, laborer, or worker classification.

All certified payrolls must list the hours worked and wages paid to All Persons who perform work ON SITE regardless of their ownership i.e.: (Owners, Corporate Officers, LLC Members, Independent Contractors, et. al)

Reporting and payment of wages is required regardless of any contractual relationship alleged to exist between the contractor and such person.

As of: September 8, 2021

Project: Meriden Public Library Renovation (Meriden)

~~Unlisted classifications needed for work not included within the scope of the classifications listed may be added after award only as provided in the labor standards contract clause (29 CFR 5.5 (a) (1) (ii)).

Please direct any questions which you may have pertaining to classification of work and payment of prevailing wages to the Wage and Workplace Standards Division, telephone (860)263-6790.

As of: September 8, 2021

CITY OF MERIDEN, CONNECTICUT

B023-24 – IT WIRING AT THE MERIDEN PUBLIC LIBRARY

AGREEMENT

This AGREEMENT, made as of this _____, 2022 by and between the City of Meriden (hereinafter the “City”) and _____ (hereinafter the “Contractor”).

WHEREAS, the City has issued a certain Invitation to Bid for Sidewalk Repairs; and

WHEREAS, the Contractor is in the business of providing such services, is the successful bidder, and has been awarded this Agreement.

NOW THEREFORE, the parties mutually agree as follows:

1. **AGREEMENT OF THE PARTIES**: The City hereby contracts for and the Contractor hereby agrees to perform the work as stated in the minimum specifications as required by the City at the locations requested.
2. **SCOPE OF SERVICES**: As per the bid proposal documents, incorporated by reference herein.
3. **TERM**: This Agreement shall begin December 15, 2022 and end January 15, 2023, unless extended or terminated.
4. **PAYMENT**: The City shall pay the Contractor in accordance with the bid proposal documents, incorporated by reference herein. Work performed without authorization will not be paid for.
5. **AUDITS**: At any time during normal business hours, and as often as maybe deemed necessary, the Contractor shall make available for examination of all records with respect to all matters covered by this Agreement and will permit authorized City, State, and/or Federal Officials to audit, inspect, examine and make excerpts or transcripts, from such records and to make audits of all contracts, invoices, payrolls, and other data relating to all matters covered by this Agreement.
6. **INDEPENDENT CONTRACTOR**: It is understood that the services of the Contractor shall be as an independent contractor and not as an employee of the City, and that persons employed by said Contractor providing services under this Agreement shall be the employees of the Contractor and not of the City.

7. INDEMNIFICATION: Contractor shall indemnify and save harmless City against any and all damages to property or injuries to or death of any person or persons, including property and employees or agents of City, and shall defend, indemnify and save harmless City from any and all claims, demands, suits, actions or proceedings of any kind or nature including workers' compensation claims, of or by anyone in any way resulting from or arising out of the operations in connection with this Agreement, including operations of subcontractors and acts or omissions of employees or agents of contractor or his or her subcontractors. Insurance coverage specified in this Agreement constitutes the minimum requirements and said requirements shall in no way lessen or limit the liability of Contractor under the terms of this Agreement. Contractor shall procure and maintain, at its own cost and expense, any additional kinds and amounts of insurance which, in its own judgment, may be necessary for his/her/its proper protection in the prosecution of the work. Contractor agrees that will well and truly save and indemnify and keep harmless the City against all liability, judgments, costs and expenses which may in any way come against owner, or which may in any way result from carelessness or neglect of contractor or its agents, employees or workmen in any respect whatever.
8. INSURANCE: The Contractor shall provide and maintain a Certificate of Insurance for the duration of this Agreement naming the City of Meriden as an ADDITIONAL INSURED and with the types and limits stated in the insurance requirements section. The Contractor agrees to provide Certificates of Insurance as requested by the City.

The contractor and its subcontractors shall comply with the Workers' Compensation Act of the State of Connecticut and shall provide compensation insurance to protect the Contractor, its subcontractors, and the City from and against any and all workers' compensation claims arising from performance of the Work under the Agreement. The City shall be furnished, prior to undertaking any work, copies of the certificate or certificates evidencing such insurance to be in effect.

9. TERMINATION: The City or the Contractor shall have the right, without cause, to terminate this Agreement within fifteen (15) days following the written notification to the other party to that effect by Certified Mail or personal delivery by agent, and upon the expiration of said fifteen (15) day period, this Agreement shall be null and void and all rights established herein shall end and terminate. It shall not be necessary for either party to state a reason for such termination.
10. BID PROPOSAL DOCUMENTS: The bid proposal documents are hereby incorporated by reference and made a part of this Agreement.
11. DEFECTIVE WORK: During a period of one year from and after the final acceptance of the work except as provided elsewhere in this Agreement, the Contractor shall, at its own expense, make all needed repairs or replacements due to defective work or materials which, in the judgment of the City, shall become necessary during this period. If within ten (10) days after the mailing of a written notice to the Contractor, or its agent, requesting repairs or replacement, the Contractor shall neglect to make or undertake with due diligence to make them, the City may make the repairs at the Contractor's expense; provided, however, that in

the case of emergency where, in the judgment of the City, delay would cause serious loss or damage, repairs or replacement may be made without notice being sent to the Contractor, and the contractor shall pay the cost.

12. GUARANTEE: The Contractor shall further guarantee that the sidewalk repairs shall remain in good order and repair for a period of five (5) years from all causes arising from defective work and materials, and to make all repairs arising from these causes during this period without further compensation, and shall guarantee the sidewalks against defective work and materials, and shall keep them in good order and repair without further compensation for a period of two (2) years from and after completion and acceptance of them by the City. The determination of the necessity for the repair or replacement of sidewalks or any portion of them, shall rest entirely with the City, whose decision upon the matter shall be final and obligatory upon the Contractor.
13. CLEAN UP: The contractor shall remove and clean up all rubbish, debris, excess material, temporary structures, tools and equipment from streets, alleys, parkways, and adjacent property that may have been used or worked on by the Contractor in connection with the Work promptly as each section or portion is completed and ready for use, leaving the same in a neat and presentable condition. Payment of monthly or partial estimates may be withheld until this has been done to the satisfaction of the City. Final acceptance and payment for the entire project will not be made until this has been fully taken care of.

During the construction, the Contractor shall keep the site of the work and adjacent premises as free from material, debris, and rubbish as is practicable and shall remove this waste entirely and at once, if, in the opinion of the city, such material, debris, or rubbish constitutes a nuisance, a safety hazard or is objectionable in any way to the public.

Upon completion and before final acceptance of the work, the Contractor shall remove from the site of the work and adjacent premises all machinery, equipment, surplus materials, falsework, excavated and useless materials, rubbish, temporary buildings, barricades and signs, and shall restore the site to the same general conditions that existed prior to the commencement of its operations. The cost of final cleaning up will not be paid for under any specific scheduled item but shall be included in the prices bid for the various items, or included in the contract lump-sum price as the case may be.

The Contractor shall clean off all cement streaks or drippings, paint smears or drippings, rust stains, oil, grease, dirt, and any other foreign materials deposited or accumulated on any portion of its work, or existing work, due to its operations.

14. CHARTERS, LAWS, AND ORDINANCES: The Contractor shall at all times observe and comply with the provisions of the charter, ordinances and regulations of the City of Meriden and of state and federal laws, rules and regulations which in any manner limit, control, or apply to the actions or operations of the contractor, its subcontractors, or the subcontractors employees, agents or servants, engaged upon the work or affecting the materials supplied to or by them

15. CONTRACTOR'S DUTIES: The Contractor shall be responsible for the completion of the Work according to the bid proposal documents, and its responsibility shall not cease until the whole work contracted for is completed and accepted. The Contractor shall keep fully informed at all times regarding all details of the work. The Contractor shall be responsible for all delays that may result in failure to install the work in the proper manner and proper time. It shall carefully study and compare all drawings, specifications, and other instructions and shall immediately report to the City any error or omission which the Contractor may discover, and shall subsequently proceed with the work in accordance with the instructions from the City concerning the error or omission. The Contractor shall furnish a competent and adequate staff as necessary for the proper administration, coordination and supervision of the work, organize the procurement of all the materials and equipment so that it will be available at the time they are needed for the work. The Contractor shall keep an adequate force of skilled workers on the job to complete the work in accordance with all requirements of the contract documents. Any employee who is considered incompetent or careless in his or her work shall be removed on demand of the engineer and replaced by a competent person.

16. LIQUIDATED DAMAGES. The Contractor acknowledges that time is of the essence for the Contractor to render its services and that the City will suffer financial loss if the Work is not completed within the times specified in paragraph 3 above. The Contractor acknowledges the expense and difficulties involved in proving the actual loss suffered by the City if the Work is not completed on time. Accordingly, instead of requiring any such proof, the City and Contractor agree that as liquidated damages for any delay (but not as a penalty), the Contractor shall pay the City TWO HUNDRED FIFTY AND NO/100 DOLLARS (\$250.00) for each day that expires after the time specified in Section 3 for substantial completion until the Work is substantially complete. After substantial completion, if Contractor neglects, refuses, or fails to complete the remaining Work within the time specified in Section 3, Contractor shall pay the City TWO HUNDRED FIFTY AND NO/100 DOLLARS (\$250.00) for each day that expires after the time specified in Section 3 for completion and readiness for final payment.

17. BLUE PENCIL PROVISION: In the event that any provision of this Agreement is unenforceable under applicable law, the validity or enforceability of the remaining provisions will not be affected. To the extent any provision of this Agreement is judicially determined to be unenforceable, a court of competent jurisdiction may reform any such provision to make it enforceable. The provisions of this Agreement will, where possible, be interpreted so as to sustain its legality and enforceability.

IN WITNESS WHEREOF, the parties hereto have set their hands and seals on the day and year indicated.

CONTRACTOR:

_____ Date: _____

Duly Authorized

CITY OF MERIDEN:

_____ Date: _____

Timothy P. Coon, City Manager
Duly Authorized



CITY OF MERIDEN, CONNECTICUT

B023-24 – IT Wiring at the Meriden Public Library

Technical Specifications

- **All Ethernet Wiring is to be CAT-6.**
- **All Ethernet Wiring is to be labeled and terminated.**
- **Contractor is responsible furnishing labor and materials for installing lockable, full-sized IT Rack in original location on the second floor. All four sides of the rack must be accessible.**
- **Please see attached spec sheets for remaining equipment.**

Rock
Needs patch panel

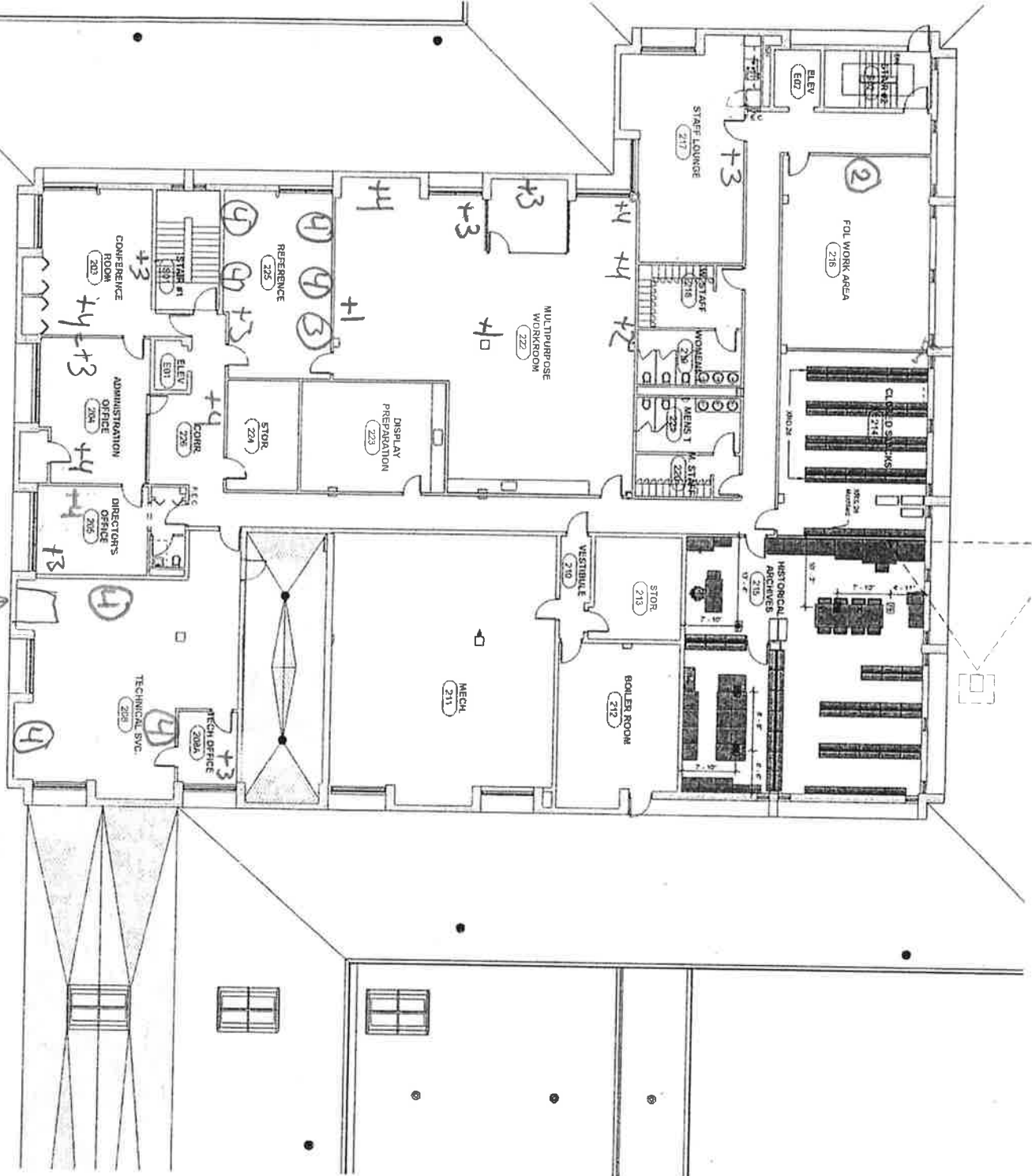

Tone+
Terminate

+ number = new run

NO.
DATE
BY
CHKD
APPV
SCALE
PROJ.
UNIT

Universal Cable Runway

Our most popular cable runway is designed for value conscious customers. The Universal Cable Runway offers the industry standard features you've come to expect. With the runway supported every 5' (1.5 m), maximum load with minimal deflection is 132 lb/ft (196 kg/m).

- Made of 3/8" x 1-1/2" x .065" (9.53 mm x 38 mm x 1.65 mm) wall rectangular steel tubing
- Cross members welded at 12" (300 mm) intervals
- Individually boxed to prevent scratches and damage
- Standard length is 9'-11 1/2"/119.5" (3035 mm)
- Underwriters Laboratory Classified for suitability as an equipment grounding conductor only (must remove paint or use ground straps)
- Installation Best Practices includes Runway Elevation Kit

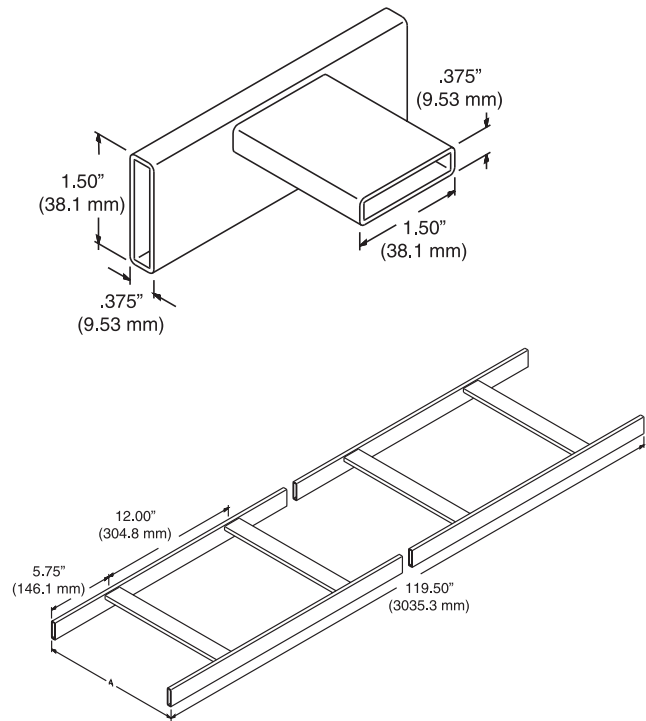

Approved
 Jasmine Scinto
 04/20/2022

ORDERING INFORMATION

Part Number	Width (Dim. A) in (mm)	Shipping Weight lb (kg)
10250-X04	4 (100)	18 (8.2)
10250-X06	6 (150)	19 (8.6)
10250-X09	9 (230)	20 (9.1)
10250-X12	12 (300)	25 (11.3)
10250-X15	15 (380)	27 (12.2)
10250-X18	18 (460)	29 (13.2)
10250-X24	24 (610)	32 (14.5)
10250-X31	30 (760)	35 (15.7)
10250-X37	36 (910)	38 (17.2)

X=color; 1=Gray, 2=Computer Beige, **7=Black**, E=Glacier White.

For product CSI Specs, visit the Support & Downloads page on www.chatsworth.com.

US & Canada

+1-800-834-4969
 Toronto, Ontario, Canada
 +905-850-7770
 chatsworth.com
 techsupport@chatsworth.com

Latin America

+52-55-5203-7525
 Toll Free within Mexico
 01-800-01-7592
 chatsworth.com.co

Europe

+44-1628-524-834
 chatsworth.com

Middle East & Africa

Dubai, UAE
 +971-4-2602125
 chatsworth.ae

Asia Pacific

+86 21 6880-0266
 chatsworth.com.cn



CHATSWORTH
 PRODUCTS

Cable Runway Load-Span Table

Maximum load with minimal deflection is 132 lb/ft when the runway is supported every 5'.

Load-Span Table, CPI Cable Runway

Safety Factor	Span (ft)	4	5	6	7	8	9
1.5	Maximum Load (lb/ft)	206	132	92	67	52	41
	Deflection (in)	0.41	0.64	0.92	1.25	1.62	2.03
2.0	Maximum Load (lb/ft)	154	99	69	50	39	31
	Deflection (in)	0.31	0.48	0.68	0.93	1.21	1.531
	K factor	0.002	0.005	0.010	0.019	0.032	0.050

CPI recommends supporting cable runway runs every 5 feet.

To calculate deflection for loads lighter than maximum loads listed in table, multiply load for which deflection is desired by K factor listed in table for cable runway support span utilized.

Example: To calculate maximum deflection using a safety factor of 1.5 for a length of cable runway supported every 5' and loaded with 80 pounds per foot:

$$\text{Deflection} = (80) (0.005) = 0.40''$$

NOTE: CPI 10250, 11252, 11275 and 14300 cable runway systems are listed under UL E138966 and tested to the requirements in the Standard for Safety for Metal Cable Tray Systems, NEMA VE 1-2009 and ANSI/NFPA 70.

United States

Agoura Hills, CA
800-834-4969

Canada

Toronto, Ontario, Canada
+905-850-7770

Europe

Buckinghamshire, UK
+441628524834

Middle East & Africa

Dubai, UAE
+971-4-2602125

Doha, Qatar
+974-4-267422

Latin America

+52-55-5203-7525
Toll Free within Mexico
800-201-7592
chatsworth.com.co

Asia Pacific

+86 21 6880-0266
chatsworth.com.cn



CHATSWORTH
PRODUCTS

Product Cut Sheet

BUTT-SPLICE KIT

Kit contains material to butt-splice 1-1/2" cable runway. Fits both solid and tubular steel 1 1/2" x 3/8" and 2" x 3/8" cable runway.

■ Kit consists of:

- 4 each splice plates
- 2 each 3/8-16 trimmed head bolts
- 2 each 3/8-16 hex nuts
- 2 each 3/8" split lock washers

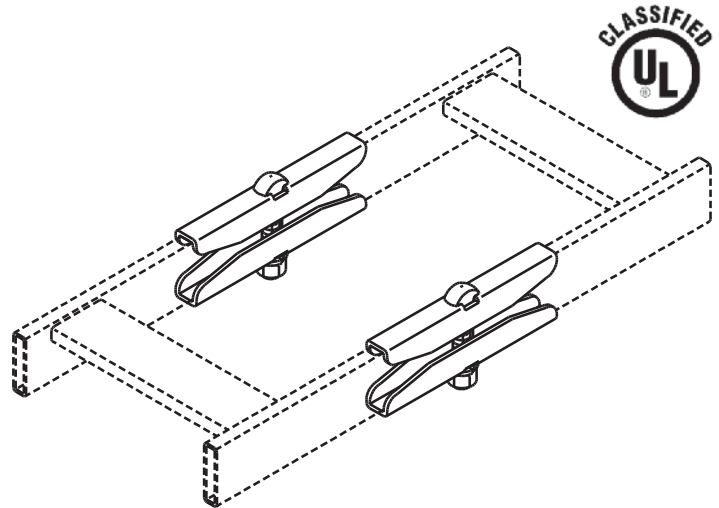

Approved

Jasmine Scinto

04/20/2022

Part Number	Description	Shipping Weight
11301-X01	Butt-Splice Kit 1 1/2" x 3/8" Stringer	1 lb
11301-X02	Butt-Splice Kit, 2" stringer	1 lb
16301-X01	U.L. Classified Kit	1 lb

* Note: X=color over zinc: 0=Gold, 7=Black

800-834-4969 in U.S. & Canada • www.chatsworth.com



CHATSWORTH PRODUCTS, INC.

©2010 Chatsworth Products, Inc. All rights reserved. CPI, CPI Passive Cooling, MegaFrame, Saf-T-Grip, Seismic Frame, SlimFrame, TeraFrame, Cube-IT Plus, Evolution, OnTrac, and QuadraRack are federally registered trademarks of Chatsworth Products, Inc. GlobalFrame, Simply Efficient and Velocity are trademarks of Chatsworth Products, Inc. All other trademarks belong to their respective companies. 12/10

Product Cut Sheet

JUNCTION-SPLICE KIT

Used to create a 90 degree junction splice with all types of 1-1/2" x 3/8" or 2" x 3/8" cable runway.

■ Kit consists of:

- 4 each corner clamp plates
- 2 each 3/8-16 x 1 3/8" trimmed head bolts
- 2 each 3/8-16 hex nuts
- 2 each 3/8 split lock washers

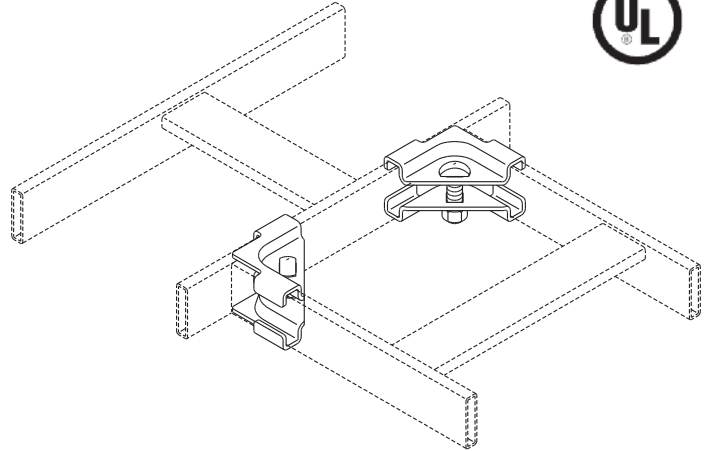

Approved

Jasmine Scinto

04/20/2022

Part Number	Description	Shipping Weight
11302-X01	Junction-Splice Kit 1 1/2" x 3/8" Stringer	1 lb
11302-X02	Junction-Splice Kit 2" x 3/8" Stringer	1 lb
16302-X01	U.L. Classified Junc. Kit	1 lb

* Note: X=color over zinc: 0=Gold, 7=Black

800-834-4969 in U.S. & Canada • www.chatsworth.com



CHATSWORTH PRODUCTS, INC.

©2010 Chatsworth Products, Inc. All rights reserved. CPI, CPI Passive Cooling, MegaFrame, Saf-T-Grip, Seismic Frame, SlimFrame, TeraFrame, Cube-iT Plus, Evolution, OnTrac, and QuadraRack are federally registered trademarks of Chatsworth Products, Inc. GlobalFrame, Simply Efficient and Velocity are trademarks of Chatsworth Products, Inc. All other trademarks belong to their respective companies. 12/10

Product Cut Sheet

J-BOLT KIT

To attach Cable Runway to Wall Angle Support, a Wall Support Bracket or to a MegaFrame® Cabinet.

Kit (wall angle/support) consists of:

- (2) 5/16-18 x 2-1/4" J-bolts (11431-001)
- (2) 5/16-18 hex nuts
- (2) 5/16 split lock washers

MegaFrame kit consists of:

- (4) 5/16-18 x 3-1/4" J-bolts
- (4) 5/16" split lock washers
- (4) 5/16-18 hex nuts

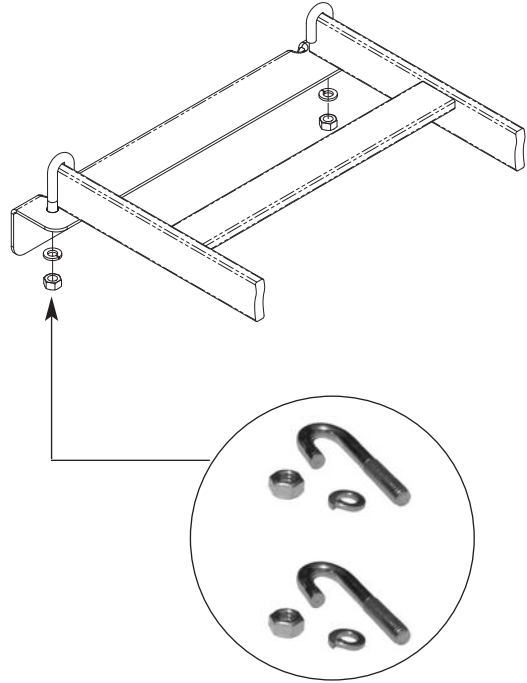

Approved

Jasmine Scinto

04/20/2022

Part Number	Color	Shipping Weight lb (kg)
11308-X01	J-Bolt Kit	1 (0.5)
11308-X05	J-Bolt Kit, MegaFrame	1 (0.5)

X=color: 0=Gold, 7=Black

+1800-834-4969 in U.S. & Canada • www.chatsworth.com



CHATSWORTH PRODUCTS, INC.

©2010 Chatsworth Products, Inc. All rights reserved. CPI, CPI Passive Cooling, MegaFrame, Saf-T-Grip, Seismic Frame, SlimFrame, TeraFrame, Cube-IT Plus, Evolution, OnTrac, and QuadraRack are federally registered trademarks of Chatsworth Products, Inc. GlobalFrame, Simply Efficient and Velocity are trademarks of Chatsworth Products, Inc. All other trademarks belong to their respective companies. 12/10

Product Cut Sheet

WALL ANGLE SUPPORT KIT, CABLE RUNWAY

2" x 2" x .105" (50 mm x 50 mm x 2.67 mm) steel support angle is designed for wall-mounting specific widths of Cable Runway.

Kit consists of:

- (1) wall angle
- (2) 5/16-18 x 2 1/4" J-bolts
- (2) 5/16-18 hex nuts
- (2) 5/16 lock washers

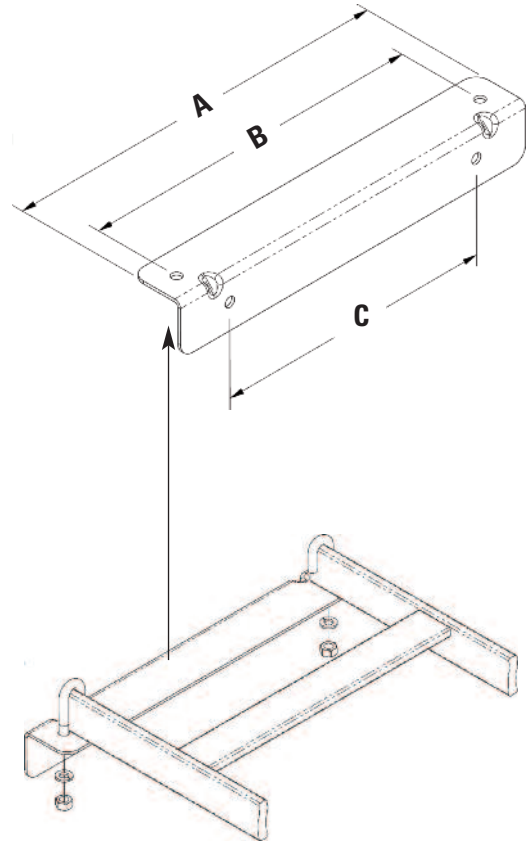

11421	Wall Angle Support Kit
--------------	-------------------------------

Color	
1	Gray
2	Computer Beige
7	Black
0	Gold
E	Glacier White

	Runway Width in (mm)	Dim. A in (mm)	Dim. B in (mm)	Dim. C in (mm)
04	4 (100)	6 (150)	4.31 (109.5)	4.31 (109.5)
06	6 (150)	8 (200)	6.31 (160.3)	4 (100.0)
09	9 (230)	11 (280)	9.31 (236.5)	7 (180.0)
10	10 (250)	12 (300)	10.21 (261.9)	8 (200.0)
12	12 (300)	14 (360)	12.31 (312.7)	10 (250.0)
15	15 (380)	17 (430)	15.31 (388.9)	13 (330.0)
18	18 (460)	20 (510)	18.31 (465.1)	16 (410.0)
20	20 (510)	22 (560)	20.31 (515.9)	18 (460.0)
24	24 (610)	26 (660)	24.31 (617.5)	22 (460.0)
30	30 (760)	32 (810)	30.31 (769.9)	28 (710.0)

11421	-	X	XX
--------------	---	----------	-----------

X=color: Gold (-0), Computer Beige (-2) and Glacier White (-E) kits have gold colored hardware. Gray (-1) and Black (-7) kits have black colored hardware.

Approved
Jasmine Scinto
04/20/2022

800-834-4969 in U.S. & Canada • www.chatsworth.com



CHATSWORTH PRODUCTS

©2013 Chatsworth Products, Inc. All rights reserved. CPI, CPI Passive Cooling, GlobalFrame, MegaFrame, Saf-T-Grip, Seismic Frame, SlimFrame, TeraFrame, Cube-IT Plus, Evolution, OnTrac, Velocity and QuadraRack are federally registered trademarks of Chatsworth Products. eConnect and Simply Efficient are trademarks of Chatsworth Products. All other trademarks belong to their respective companies. 6/13

Cable Runway Radius Drop

Mounts to the cross member of CPI Cable Runway to help maintain proper Category 5e/6/6a or fiber bend radius.

- Quick and easy installation
- Cross Member Radius Drop (P/N 12100-XXX) fits 6", 9", 12" and 18"W (150 mm, 230 mm, 300 mm and 460 mm) cross member tubing on CPI Universal Runway (Series 10250)
- Provides 3" (80 mm) bend radius
- Products 5"W (130 mm), 12100-X06, drop into CPI's 6"W (150 mm) vertical cabling sections
- Supplied with 1-1/2" (38.1 mm) cable spools (P/N 15003-001) to separate and guide cables
- Sold individually

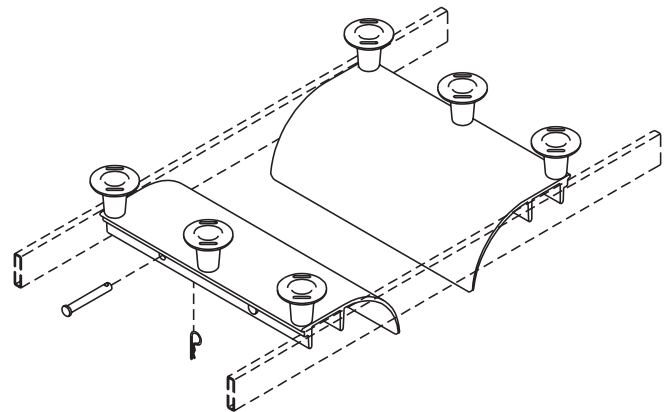

Approved
 Jasmine Scinto
 04/20/2022

ORDERING INFORMATION

Part Number	Cable Runway Width in (mm)	Product Width in (mm)	Cable Spools
12100-X06	6 (150)	5 (130)	2 each
12100-X09	9 (230)	8 (200)	2 each
12100-X12	12 (300)	11 (280)	3 each
12100-X18	18 (460)	17 (430)	3 each

X=color: 1=Gray, Computer Beige, 7=Black, E=Glacier White.

For product CSI Specs, visit the Support & Downloads page on www.chatsworth.com.

US & Canada

+1-800-834-4969
 Toronto, Ontario, Canada
 +905-850-7770
chatsworth.com
techsupport@chatsworth.com

Latin America

+52-55-5203-7525
 Toll Free within Mexico
 01-800-01-7592
chatsworth.com.co

Europe

+44-1628-524-834
chatsworthproducts.co.uk

Middle East & Africa

Dubai, UAE
 +971-4-2602125
chatsworth.ae

Asia Pacific

+86 21 6880-0266
chatsworth.com.cn



CHATSWORTH
 PRODUCTS

Velocity® Cable Management for CPI Rack Systems

An economical cable management solution for CPI Rack Systems. Create vertical and horizontal pathways that store and organize premise cables and patch cords on two- and four-post Rack Systems.

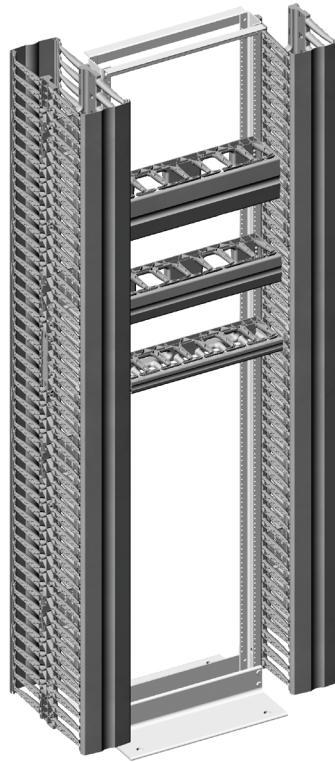

ADVANTAGES

- ➔ **Increased Cable Capacity**
Single-sided vertical managers are deeper to provide more cable capacity
- ➔ **Compact Packaging**
Reduces waste, freight costs and uses less storage space.
- ➔ **Simplified Cable Management**
Optimize cable pathways using the integrated T-shaped cable guides and protect cables with snap-on covers
- ➔ **Tool-less Assembly**
Components snap together for quick and easy assembly

PATENTED

KEY FEATURES

- Quick and easy tool-less snap together design takes approximately 3 - 5 minutes to unpack, assemble and install
- Compact packaging is 25% - 57% smaller than comparable managers, easy to ship, requires less storage space, reduces waste and makes cartons easier to handle
- Larger cross-section on single-sided vertical managers provides up to 1/3 more cable management space
- Openings on the side of the manager align with each rack-mount unit
- T-shaped cable guides provide more space between fingers to organize cables by rack-mount unit
- Rounded edges on cable guides and openings protect cables as they enter and exit the manager
- Openings in the back of the manager allow easy front-to-rear cabling
- Snap-on covers secure and protect cables

SPECIFICATIONS

Description	Vertical and horizontal cable managers for open two- and four-post CPI Rack Systems For indoor use only, in environmentally controlled areas; may not be used outdoors, in harsh environments or in air-handling spaces
Single-Sided Cable Manager Includes:	Four vertical side sections with T-shaped cable guides (fingers) spaced 1U apart Four mid panels with attachment points for cable management accessories Two splice plates used to assemble the top and bottom side sections Two half-height covers that snap onto the T-shaped cable guides Eight M8 hex bolts, washers and hex flange nuts to secure cable managers to the rack
Double-Sided Cable Manager Includes:	Four vertical side sections with T-shaped cable guides (fingers) spaced 1U apart Four mid panels with attachment points for cable management accessories Two splice plates used to assemble the top and bottom side sections Four half-height covers that snap onto the T-shaped cable guides Eight M8 hex bolts, washers and hex flange nuts to secure cable managers to the rack
Horizontal Cable Manager Includes:	One 19"W EIA rack-mount cable manager with T-shaped cable guides (fingers) One cover that snaps onto the T-shaped cable guides Four #12-24 x 1" rack-mount screws and four M6 x 25 mm rack-mount screws
Construction:	Snaps together
Finish:	Black epoxy-polyester hybrid powder coat paint on steel parts; black plastic

Availability Statement

US & Canada

+1-800-834-4969
Toronto, Ontario, Canada
+905-850-7770
chatsworth.com
techsupport@chatsworth.com

Latin America

+52-55-5203-7525
Toll Free within Mexico
01-800-01-7592
chatsworth.com.co

Europe

+44-1628-524-834
chatsworthproducts.co.uk

Middle East & Africa

Dubai, UAE
+971-4-2602125
chatsworth.ae

Asia Pacific

+86 21 6880-0266
chatsworth.com.cn



CHATSWORTH
PRODUCTS

SPECIFICATIONS

Packaging:	Each vertical cable manager ships unassembled in a single carton Each horizontal cable manager ships fully assembled in a single carton
Sizes:	See ordering information at right
Cable Fill:	See cable fill table at www.chatsworth.com/cablefill
Material:	Vertical cable manager has steel mid panels and splice plates and plastic sides; covers on 3.6"W (91mm) and 6"W (152 mm) managers are plastic; covers on 10"W (254 mm) and 12" (305 mm) managers are steel with plastic hinges Horizontal cable manager is plastic
Finish:	

USE WITH

- Standard Rack 3"D (80 mm)
- QuadraRack™ Server Frame
- QuadraRack™ 4-Post Frame
- Adjustable QuadraRack™
- Adjustable ServerRack
- Adjustable Rail QuadraRack™
- Adjustable Rail ServerRack

RELATED PRODUCTS

- Cable Spool Kit
- Cable Lashing Bar Kit
- Cable Ring Kit
- Jumper Trays
- Patch Panel Wire Management Bar

Design

Velocity Cable Management includes single- and double-sided vertical cable managers available in four widths and three heights, and matching single-sided horizontal cable managers in three heights. The vertical cable managers ship unassembled in compact packaging to reduce shipping costs and storage space, providing easier staging and handling on the job site with less packaging to remove. No tools are required to assemble the cable manager. The components simply snap together and the manager bolts to the side of the rack with included hardware.

The vertical cable manager features a large cross section to maximize internal cable management space. To simplify cable management, T-shaped cable guides and openings on the sides of the manager align with each rack-mount unit and have rounded edges to protect cables from snags. Snap-on covers are included and swing open to the right or left to provide easy access and protect cables when closed. The manager has openings in the body which allow cables to pass easily front-to-rear. Add the accessory Cable Spool Kit to manage fiber, the Cable Lashing Bar Kit to secure large cable bundles or the Cable Ring Kit to create a rear pathway on the back of single-sided managers.

The horizontal cable manager ships fully assembled and also features T-shaped cable guides at the top and bottom of the manager to organize patch cords. Two cable openings in the rear of the manager allow front-to-rear cabling and the snap-on cover stays in the opened position to provide easy access to cables.

See inside for product details. Contact CPI Technical Support for configurations assistance.



Features quick and easy tool-less snap together design that takes approximately 3 - 5 minutes to unpack, assemble and install

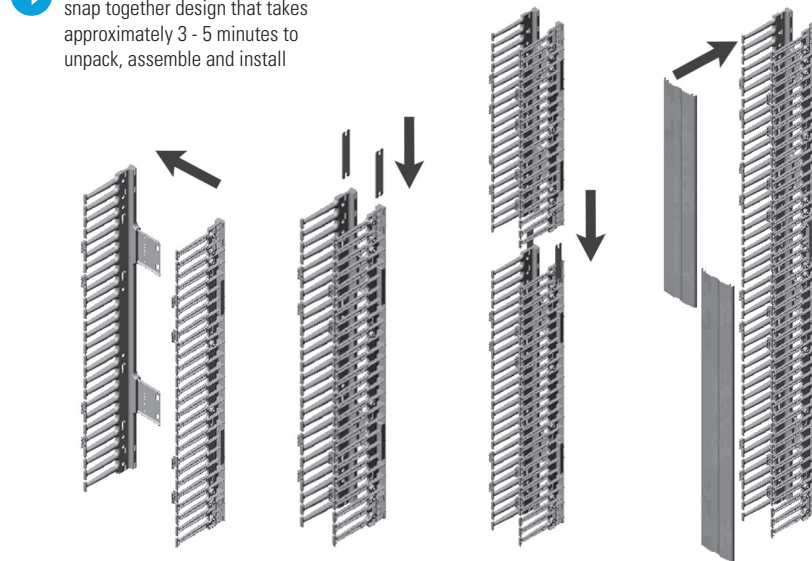

Step 1: Insert mid panel into plastic cable side section

Step 2: Insert the two splice plates into the slots at the end of each side section

Step 3: Slide the top side section onto the protruding ends of the splice plates until fully seated

Step 4: Mount each cover by positioning over the hinges and pressing firmly to snap into place

ORDERING INFORMATION

Part Number	Single-Sided Vertical Cable Managers H x W x D in (mm)	Shipping Weight lb (kg)
For 6'H (1.8 m), 38U Racks		
13901-701	70 x 3.6 x 9.7 (1778 x 91 x 246)	17 (7.7)
13902-701	70 x 6 x 9.8 (1778 x 152 x 249)	19 (8.2)
13904-701	70 x 10 x 10.3 (1778 x 254 x 262)	30 (13.6)
13905-701	70 x 12 x 10.4 (1778 x 305 x 264)	32 (14.5)
For 7'H (2.1 m), 45U Racks		
13901-703	80.5 x 3.6 x 9.7 (2045 x 91 x 246)	18 (8.2)
13902-703	80.5 x 6 x 9.8 (2045 x 152 x 249)	20 (9.1)
13904-703	80.5 x 10 x 10.3 (2045 x 254 x 262)	32 (14.5)
13905-703	80.5 x 12 x 10.4 (2045 x 305 x 264)	34 (15.4)
For 8'H (2.4 m), 51U Racks		
13901-715	91 x 3.6 x 9.7 (2311 x 91 x 246)	18 (8.2)
13902-715	91 x 6 x 9.8 (2311 x 152 x 249)	20 (9.1)
13904-715	91 x 10 x 10.3 (2311 x 254 x 262)	32 (14.5)
13905-715	91 x 12 x 10.4 (2311 x 305 x 264)	34 (15.4)

Notes: Color is Black. Velocity Single-Sided Vertical Cable Managers are 9.5 inches deep (241 mm) without doors. The overall depth listed in the order table varies due to the bevel on the door which differs slightly with width. Usable depth is 7.5 inches (191 mm). Usable width is 1.3 inches (33 mm) less than overall width.

Part Number	Double-Sided Vertical Cable Managers H x W x D in (mm)	Shipping Weight lb (kg)
For 6'H (1.8 m), 38U Racks		
13911-701	70 x 3.6 x 16.4 (1778 x 91 x 417)	23 (10.4)
13912-701	70 x 6 x 16.6 (1778 x 152 x 422)	26 (11.8)
13914-701	70 x 10 x 17.5 (1778 x 254 x 445)	37 (16.8)
13915-701	70 x 12 x 17.8 (1778 x 305 x 446)	40 (18.1)
For 7'H (2.1 m), 45U Racks		
13911-703	80.5 x 3.6 x 16.4 (2045 x 91 x 417)	25 (11.8)
13912-703	80.5 x 6 x 16.6 (2045 x 152 x 422)	28 (12.7)
13914-703	80.5 x 10 x 17.5 (2045 x 254 x 445)	40 (18.1)
13915-703	80.5 x 12 x 17.8 (2045 x 305 x 446)	43 (19.5)
For 8'H (2.4 m), 51U Racks		
13911-715	91 x 3.6 x 16.4 (2311 x 91 x 417)	27 (12.2)
13912-715	91 x 6 x 16.6 (2311 x 152 x 422)	30 (13.6)
13914-715	91 x 10 x 17.5 (2311 x 254 x 445)	44 (20.0)
13915-715	91 x 12 x 17.8 (2311 x 305 x 446)	47 (21.3)

Notes: Color is Black. Velocity Double-Sided Vertical Cable Managers are 16 inches deep (406 mm) without doors. The overall depth listed in the order table varies due to the bevel on the door which differs slightly with width. Usable depth in the front of the manager is 7.5 inches (191 mm). Usable depth at the rear of the manager is 5.5 inches (140 mm). Usable width is 1.3 inches (33 mm) less than overall width.

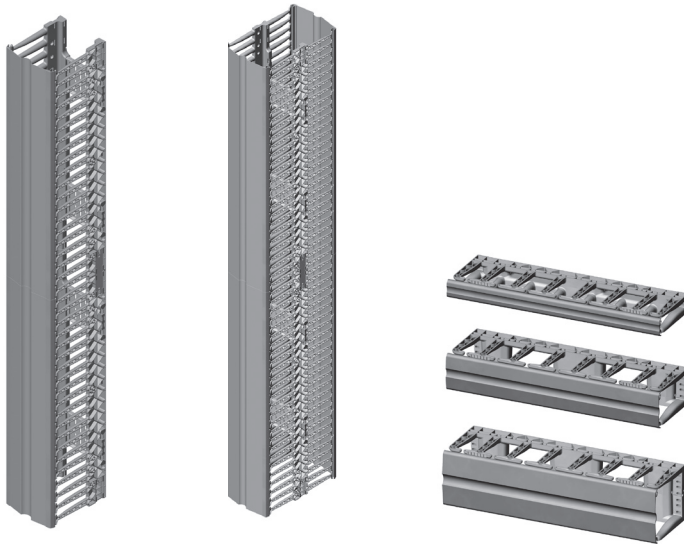

Single-Sided (13905-703)

Double-Sided (13915-703)

Approved
 Jasmine Scinto
 04/20/2022

Single-Sided Horizontal Cable Managers		
Part Number	Description H x W x D in (mm)	Shipping Weight lb (kg)
13930-701	1U x 19 x 5.9 (150)	2 (0.9)
13930-702	2U x 19 x 5.9 (150)	3 (1.4)
13930-703	3U x 19 x 5.9 (150)	3 (1.4)

Notes: Color is Black. 1U = 1.75 inches (44.45 mm); the overall height of the manager is .03 inches (0.16 mm) less than the full rack-mount unit height. Usable depth is 3.7 inches (94 mm). The usable height of the manager varies but is 1.2 inches (31 mm) less than the overall height of the manager at the narrowest point.

ACCESSORIES

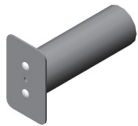

Cable Spool Kit

The Cable Spool Kit includes four small cable spools to provide slack management and strain relief for patch cords and jumper cables inside the Velocity Vertical Cable Managers.

- Use in 6"W (152 mm) or wider vertical cable managers; one kit per side
- Attaches to the mid panel with included hardware
- Spools are 2" (51 mm) in diameter and 6"L (152 mm)
- Made from aluminum; painted black
- Each kit includes four spools and mounting hardware

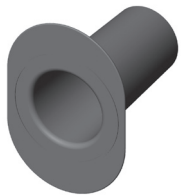

Cable Distribution Spools

Cable Distribution Spools provide slack management and strain relief for patch cords and jumper cables inside Velocity Vertical Cable Managers.

- Use in 10"W (254 mm) or 12"W (305 mm) vertical cable manager, (will not fit in other sizes)
- Attaches to the mid panel with included hardware
- Spools are 2.75" (69.9 mm) in diameter and 5.9"L (150 mm)
- Made from black plastic
- Each kit includes four spools and mounting hardware



Cable Distribution Spool Spacer Kit

Cable Distribution Spool Spacer Kit includes eight spacers that are used with the Cable Distribution Spools (P/N 15008-001) inside Velocity Vertical Cable Managers to offset the spool so that the front edge of the spool is close to the front edge of the cable management fingers.

- Use in 10"W (254 mm) or 12"W (305 mm) vertical cable managers; use on the front side of double-sided managers only
- Attaches to the mid panel with included hardware
- Spacers are 2.8" (71 mm) in diameter and 2.5"L (64 mm)
- Made from black plastic
- Each kit includes eight spacers and mounting hardware



Cable Lashing Bar Kit

The Cable Lashing Bar Kit provides tie points for cables inside Velocity Vertical Cable Managers.

- Use in 6"W (152 mm) or wider vertical cable managers; one kit per side
- Attaches to the rear/mid panel with included hardware
- Bars are .23" (5.7 mm) in diameter; two bars are 23.7"L (602 mm); four bars are 16.6"L (422 mm)
- Made from steel; zinc-plated, silver-colored
- Each kit includes six lashing bars and mounting hardware

Velocity Cable Management for Rack Systems		
Part Number	Description H x W ft (m) x in (mm)	Shipping Weight lb (kg)
13935-701	Cable Spool Kit, Black, Pack of 4	2 (0.9)
15008-001	Distribution Spools, Black, Pack of 4	2 (0.9)
35505-001	Distribution Spool Spacer Kit, Black	1 (0.5)
13928-001	Cable Lashing Bar Kit, Zinc Plated, Silver	2 (0.9)
13934-716	Cable Ring Kit, For 3.6"W (91 mm) x 6"H (1.8 m) Managers	8 (3.6)
13934-717	Cable Ring Kit, For 3.6"W (91 mm) x 7"H (2.1 m) Managers	9 (4.1)
13924-718	Cable Ring Kit, For 3.6"W (91 mm) x 8"H (2.4 m) Managers	11 (5.0)
13934-726	Cable Ring Kit, For 6"W (152 mm) x 6"H (1.8 m) Managers	9 (4.1)
13934-727	Cable Ring Kit, For 6"W (152 mm) x 7"H (2.1 m) Managers	11 (5.0)
13934-728	Cable Ring Kit, For 6"W (152 mm) x 8"H (2.4 m) Managers	12 (5.4)
13934-746	Cable Ring Kit, For 10"W (254 mm) x 6"H (1.8 m) Managers	12 (5.4)
13934-747	Cable Ring Kit, For 10"W (254 mm) x 7"H (2.1 m) Managers	14 (6.4)
13934-748	Cable Ring Kit, For 10"W (254 mm) x 8"H (2.4 m) Managers	15 (6.8)
13934-756	Cable Ring Kit, For 12"W (305 mm) x 6"H (1.8 m) Managers	14 (6.4)
13934-757	Cable Ring Kit, For 12"W (305 mm) x 7"H (2.1 m) Managers	16 (7.3)
13934-758	Cable Ring Kit, For 12"W (305 mm) x 8"H (2.4 m) Managers	18 (8.2)



Cable Ring Kit

The Cable Ring Kit creates a separate cable pathway on the back of a Velocity Single-Sided Vertical Cable Manager for premise cables.

- Match the kit to the width and height of the vertical cable managers; one kit per manager
- Attaches to the sides with included hardware
- Rings are C-shaped, 3.0"H x 7.7"D (76 mm x 196 mm), with a plastic latch that spins open to provide access to cables
- Cable opening on 3.6"W (91 mm) rings is 1.4"W (36 mm); cable opening on other rings is 3.8"W (97 mm)
- Rings are made from aluminum and painted black; latch is black plastic
- Each kit includes multiple rings and mounting hardware. The (-7X6) kits include six rings, the (-7X7) kits include seven rings, the (-7X8) kits include eight rings
- Color is black.



Scan or click here to visit our CPI Online Catalog.

For product CSI Specs visit the Support & Downloads page on www.chatsworth.com.



CHATSWORTH PRODUCTS

While every effort has been made to ensure the accuracy of all information, CPI does not accept liability for any errors or omissions and reserves the right to change information and descriptions of listed services and products. ©2016 Chatsworth Products, Inc. All rights reserved. Chatsworth Products, CPI, CPI Passive Cooling, eConnect, MegaFrame, Saf-T-Grip, Seismic Frame, SlimFrame, TeraFrame, GlobalFrame, Cube-IT Plus, Evolution, OnTrac, QuadraRack and Velocity are federally registered trademarks of Chatsworth Products. Simply Efficient is a trademark of Chatsworth Products. All other trademarks belong to their respective companies. Rev.2 01/16 MKT-60020-475

Product Cut Sheet

UNIVERSAL HORIZONTAL CABLE MANAGER

Create an attractive and highly functional horizontal pathway for patch cords and multimedia applications using coax, copper and fiber optic cables. After routing the cables or cords, simply snap on the cover for a clean, professional appearance.

- Extra-wide and contoured cable guide fingers, spaced 1.75" (44.5 mm) apart, separate and organize patch cords for quick and easy moves, adds and changes.
- The cable guides are offset to ensure proper bending radii of patch cables, even hooded patch cables
- Patented fingers meet the requirements of UL 94V-0 flammability rating
- Snap-on covers are easy to use and open 180° up or down with adjacent installation
- Covers and panel have a black powder-coat textured finish, reducing fingerprints and smudges

Estimated cable capacities:

See the cable fill table at www.chatsworth.com/cablefill

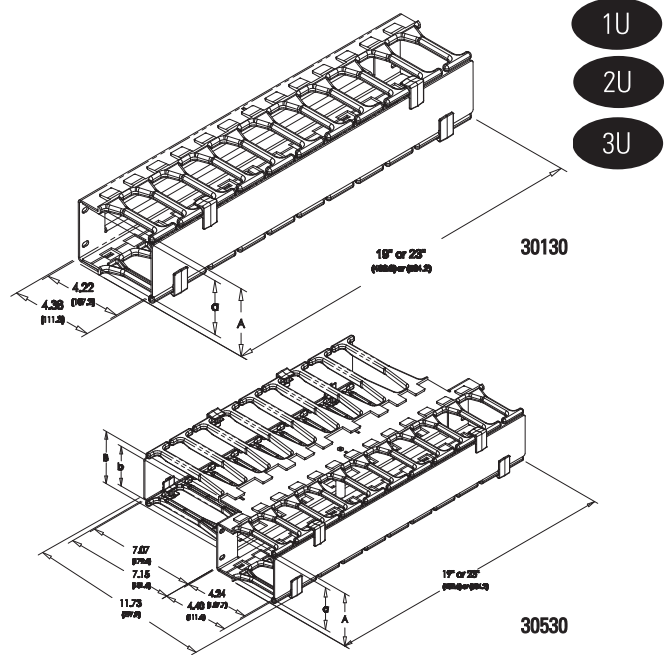

Double-Sided Cable Manager		
Part Number	Description H x W x D in (mm)	Shipping Weight lb (kg)
30529-X19	1U x 19 x 11.73 (297.9)	5 (2.3)
30529-X23	1U x 23 x 11.73 (297.9)	6 (2.7)
30530-X19	2U x 19 x 11.73 (297.9)	6 (2.7)
30530-X23	2U x 23 x 11.73 (297.9)	7 (3.2)
30531-X19	3U x 19 x 11.73 (297.9)	6 (2.7)
30531-X23	3U x 23 x 11.73 (297.9)	7 (3.2)

Single-Sided Cable Manager		
Part Number	Description H x W x D in (mm)	Shipping Weight lb (kg)
30139-X19	1U x 19 x 4.96 (126.0)	2 (0.9)
30139-X23	1U x 23 x 4.96 (126.0)	3 (1.4)
30130-X19	2U x 19 x 5.14 (130.6)	3 (1.4)
30130-X23	2U x 23 x 5.14 (130.6)	4 (1.8)
30131-X19	3U x 19 x 5.14 (130.6)	4 (1.8)
30131-X23	3U x 23 x 5.14 (130.6)	5 (2.3)
30339-X19*	1U x 19 x 6.26 (159.0)	3 (1.4)
30339-X23*	1U x 23 x 6.26 (159.0)	3 (1.4)
30330-X19*	2U x 19 x 6.44 (163.6)	4 (1.8)
30330-X23*	2U x 23 x 6.44 (163.6)	5 (2.3)
30331-X19*	3U x 19 x 6.44 (163.6)	5 (2.3)
30331-X23*	3U x 23 x 6.44 (163.6)	6 (2.7)

X=Color: 7=Black, E=Glacier White. *Note: Deep Panel is used when Double-Sided MCS Master Cabling Sections are center-mounted on 3"D racks.

Part Number	Dimensions					
	19"	23"	A	a	B	b
30139-719		30139-723	1.73 (43.9)	1.02 (25.9)		
30130-719		30130-723	3.48 (88.4)	2.77 (70.4)		
30131-719		30131-723	5.23 (132.8)	4.52 (114.8)		
30339-719		30339-723	1.73 (43.9)	1.02 (25.9)		
30330-719		30330-723	3.48 (88.4)	2.77 (70.4)		
30331-719		30331-723	5.23 (132.8)	4.52 (114.8)		
30529-719		30529-723	1.73 (43.9)	1.00 (25.4)	1.67 (42.4)	0.85 (21.6)
30530-719		30530-723	3.46 (87.9)	2.75 (69.9)	3.42 (86.9)	2.60 (66.0)
30531-719		30531-723	5.23 (132.8)	4.50 (114.3)	5.17 (131.3)	4.44 (112.8)

Use Universal Horizontal Cable Manager in conjunction with the CPI Patch Panel Wire Management Bar (P/N 12176-X01) and any of CPI's vertical cabling sections for clean, organized cable management.

Approved
Jasmine Scinto
04/20/2022

DA Comment - Furnish as noted.

800-834-4969 in U.S. & Canada • www.chatsworth.com

Universal Rack

Use with vertical and horizontal cable managers to support interconnect and network equipment in telecommunications rooms, equipment rooms and data centers. Use with shelves to support equipment.



ADVANTAGES

- ➔ **Marked and Numbered rack-mount units (U)**
U marks simplify equipment installation
- ➔ **Bonding Studs**
Located directly on rack channel
- ➔ **Mounting**
Holes in base angle for floor attachment



KEY FEATURES

- Supports 19" rack-mount equipment designed for two-post panel mounting like patch panels and network switches or use with shelves to support computer servers.
- Easy positioning of equipment or shelves with marked and numbered rack-mount spaces.
- Quick attachment of equipment with threaded equipment mounting holes and included equipment-mounting screws.
- Delivers unassembled in a single carton — quick and easy bolt-together assembly takes less than 10 minutes.
- Lightweight aluminum construction for easy transport and positioning during installation.
- Integrated grounding with a built-in attachment point for a ground (earthing) connection.
- Attach CPI vertical cable managers to the side of the rack through pre-punched holes.
- Secure the rack to the floor quickly with a concrete, wood or raised floor installation kit through pre-punched holes in base angle.



SPECIFICATIONS

Description	Open floor-mount two-post rack supports 19"W EIA, 23"W or 35"W rack-mount equipment
Use	For indoor use only, in environmentally controlled areas; may not be used outdoors, in industrial or harsh environments, or in plenum spaces
Available sizes	Heights: See Dimension Table
	Width: 20.3" (515.9 mm), 24.3" (617.5 mm), 26.3" (922.3 mm) Depth: 15" (381 mm)
Equipment space	Heights: See Dimension Table
	Width: 19" EIA (17-3/4" clearance), 23" (21-3/4" clearance), 35" (33-3/4" clearance) Depth: 20"D (508 mm)
Cable Management	Use vertical and horizontal cable managers, sold as accessories
Load capacity	1,500 lb (680.4 kg) of equipment; weight must be evenly distributed, and rack must be properly secured to floor
Bonding/Grounding	Top angles, base angles and side channels are electrically bonded by assembly hardware - One exception - top angles are not electrically bonded on Flush Bolted Racks (P/N 467XX) - A masked mounting location for ground lug with two 1/4-20 threaded studs spaced 5/8" apart is provided inside the side channel - Racks that are over 6'H (1.8 m) have top and bottom mounting locations - Use the CPI Grounding Jumper (P/N 40159-008) as a rack bonding conductor
Certifications	EIA-310-D compliant - Select models are UL Listed as a communications circuit accessory - OSHPD Preapproval of Manufacturer's Certification (OPM-0261-13)
Material	Aluminum extrusion
Construction	Bolted assembly, Ships unassembled
Finish	Clear grained aluminum or Epoxy-polyester hybrid powder coat paint. Available in black, gray, computer beige or glacier white

Availability Statement

United States

Agoura Hills, CA
800-834-4969

Canada

Toronto, Ontario, Canada
+905-850-7770
chatsworth.com • techsupport@chatsworth.com

Europe

Buckinghamshire, UK
+441628524834

Middle East & Africa

Dubai, UAE
+971-4-2602125

Doha, Qatar
+974-4-267422

Latin America

+52-55-5203-7525
Toll Free within Mexico
800-201-7592
chatsworth.com.co

Asia Pacific

Shanghai
+86 21 6880-0266
chatsworth.com.cn



CHATSWORTH
PRODUCTS

ORDERING MATRIX:

- UL Listed racks offered in multiple heights and 19" or 23" widths
- For heavy-duty, high-capacity installations.

Top Bar or Angles	
460	Two Top Bars
463	Two Top Angles
467	Two Top Angles, Flush Bolted
483	UL Listed (With Two Top Angles)

Width - in	
5	19 EIA Channel
8	23 Channel

Mounting Holes	
3	Mounting Holes Both Sides

Color	
1	Gray
2	Computer Beige
5	Clear
7	Black
E	Glacier White

Height		
31	3 (0.9)	17U
20	4 (1.2)	24U
19	5 (1.5)	31U
00	5.6 (1.7)	34U
01	6 (1.8)	38U
02	6.6 (2.0)	41U
03	7 (2.1)	45U
05	7.6 (2.3)	48U
15	8 (2.4)	51U
17	8.6 (2.6)	55U
08	9 (2.7)	58U

4XX	X	X	-	X	XX
-----	---	---	---	---	----

Approved
 Jasmine Scinto
 04/20/2022

Universal Rack is a heavy duty storage solution for patch panels and network switches and can be used with shelves to hold computer servers. Universal Rack uses less floor space than a cabinet or a four-post rack. Use Universal Rack in telecommunications rooms or equipment rooms to save floor space and hold heavy equipment.

Universal Rack meets project specifications. Universal Rack holds 1,500 lb (680.4 kg) of equipment, has integrated grounding and is available UL and cUL Listed as a communications circuit accessory. Universal Rack supports 19", 23" or 35" wide rack-mount equipment and shelves and is available in several heights. Equipment attaches to the front or rear of the 3"D (76 mm) vertical mounting channels with screws. Equipment mounting positions are marked and numbered making it easy to position and install equipment or shelves.

Racks deliver unassembled in a compact carton. Universal Rack is easy to assemble. Components bolt together with included hardware. Assembly holes in the rack uprights are threaded. Assembly takes approximately 10 minutes. Two-post racks must be secured to building structure. Universal Rack has pre-punched base angles making it easy to attach the rack to the floor. Use a CPI installation kit for wood, slab or raised floors.

Most Universal Rack applications require cable management. Vertical cable managers attach directly to the side of Universal Rack. CPI cable managers organize cables by-rack-mount-space simplifying future moves, adds and changes to the network. The best solution includes horizontal managers in between patch panels and network switches to fan patch cords into individual port connections. See reverse for product selection.

DIMENSIONS

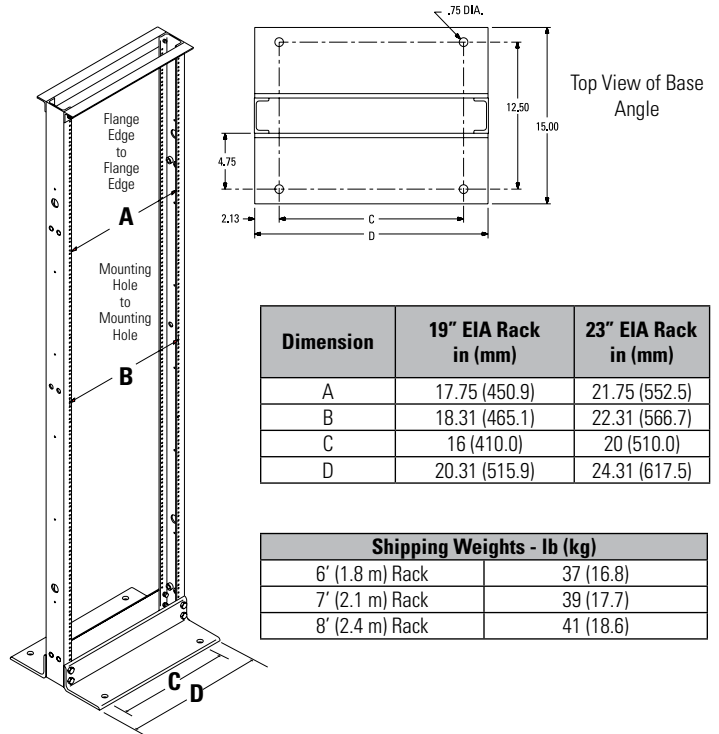

Dimension	19" EIA Rack in (mm)	23" EIA Rack in (mm)
A	17.75 (450.9)	21.75 (552.5)
B	18.31 (465.1)	22.31 (566.7)
C	16 (410.0)	20 (510.0)
D	20.31 (515.9)	24.31 (617.5)

Shipping Weights - lb (kg)	
6' (1.8 m) Rack	37 (16.8)
7' (2.1 m) Rack	39 (17.7)
8' (2.4 m) Rack	41 (18.6)

For product CSI Specs visit the Support & Downloads page on chatsworth.com.

PART NUMBERS AND PHYSICAL CHARACTERISTICS

Listing	Part Number	Pair Count	Jacket Color	Nominal Diameter in (mm)	Approx. Weight lbs/kft (kg/km)	Package	Packages per Pallet
CMR	18-042-13	2	Beige	0.12 (3.1)	9 (13)	1,000' POP™ box	45
CMR	18-042-33	2	Gray	0.12 (3.1)	9 (13)	1,000' POP box	45
CMR	18-141-13	3	Beige	0.14 (3.5)	12 (18)	1,000' POP box	45
CMR	18-141-33	3	Gray	0.14 (3.5)	12 (18)	1,000' POP box	45
CMR	18-241-13	4	Beige	0.16 (3.9)	15 (22)	1,000' POP box	45
CMR	18-241-23	4	Blue	0.16 (3.9)	15 (22)	1,000' POP box	45
CMR	18-241-33	4	Gray	0.16 (3.9)	15 (22)	1,000' POP box	45
CMR	18-241-43	4	White	0.16 (3.9)	15 (22)	1,000' POP box	45
CMR	18-341-13	6	Beige	0.19 (4.8)	22 (32)	1,000' POP box	45
CMR	18-341-33	6	Gray	0.19 (4.8)	22 (32)	1,000' POP box	45
CMR	18-872-13	12	Beige	0.27 (6.9)	47 (71)	1,000' Plywood reel	16
CMR	18-872-33	12	Gray	0.27 (6.9)	47 (71)	1,000' Plywood reel	16
CMR	18-475-13	25	Beige	0.38 (9.6)	92 (137)	1,000' Plywood reel	12
CMR	18-499-13	25	Beige	0.38 (9.6)	92 (137)	Cut to length	1
CMR	18-475-33	25	Gray	0.38 (9.6)	92 (137)	1,000' Plywood reel	12
CMR	18-499-33	25	Gray	0.38 (9.6)	92 (137)	Cut to length	1
CMR	18-579-13	50	Beige	0.56 (14.2)	187 (279)	1,000' Plywood reel	4
CMR	18-599-13	50	Beige	0.56 (14.2)	187 (279)	Cut to length	1
CMR	18-579-33	50	Gray	0.56 (14.2)	187 (279)	1,000' Plywood reel	4
CMR	18-599-33	50	Gray	0.56 (14.2)	187 (279)	Cut to length	1
CMR	18-789-13	100	Beige	0.74 (18.7)	361 (538)	Cut to length	1
CMR	18-789-33	100	Gray	0.74 (18.7)	361 (538)	Cut to length	1
CMR	18-D99-33	150	Gray	0.92 (23.4)	541 (807)	Cut to length	1
CMR	18-A99-33	200	Gray	1.05 (26.6)	711 (1,060)	Cut to length	1
CMR	18-B99-33	300	Gray	1.27 (32.2)	1,049 (1,564)	Cut to length	1
CMR	18-C99-33	400	Gray	1.45 (36.9)	1,386 (2,067)	Cut to length	1
CMP	18-041-36	2	Gray	0.13 (3.3)	10 (15)	1,000' POP box	45
CMP	18-141-36	3	Gray	0.15 (3.7)	14 (20)	1,000' POP box	45
CMP	18-241-26	4	Blue	0.16 (4.2)	17 (26)	1,000' POP box	45
CMP	18-241-36	4	Gray	0.16 (4.2)	17 (26)	1,000' POP box	45
CMP	18-241-46	4	White	0.16 (4.2)	17 (26)	1,000' POP box	45
CMP	18-241-56	4	Green	0.16 (4.2)	17 (26)	1,000' POP box	45
CMP	18-341-36	6	Gray	0.20 (5.0)	24 (37)	1,000' POP box	45
CMP	18-341-46	6	White	0.20 (5.0)	24 (37)	1,000' POP box	45
CMP	18-872-46	12	White	0.30 (7.6)	49 (73)	1,000' Plywood reel	16
CMP	18-475-36	25	Gray	0.43 (10.9)	114 (171)	1,000' Plywood reel	12
CMP	18-499-36	25	Gray	0.43 (10.9)	114 (171)	Cut to length	1
CMP	18-475-46	25	White	0.43 (10.9)	114 (171)	1,000' Plywood reel	12
CMP	18-499-46	25	White	0.43 (10.9)	114 (171)	Cut to length	1
CMP	18-579-36	50	Gray	0.60 (15.3)	227 (339)	1,000' Plywood reel	4
CMP	18-599-36	50	Gray	0.60 (15.3)	227 (339)	Cut to length	1
CMP	18-799-36	100	Gray	0.84 (21.3)	446 (665)	Cut to length	1
CMP	18-799-46	100	White	0.84 (21.3)	446 (666)	Cut to length	1
CMP	18-A99-36	200	Gray	1.16 (29.4)	850 (1,268)	Cut to length	1
CMP	18-B99-36	300	Gray	1.44 (36.7)	1,315 (1,960)	Cut to length	1
CMP	18-B99-46	300	White	1.44 (36.7)	1,315 (1,961)	Cut to length	1
CMP	18-C99-36	400	Gray	1.64 (41.7)	1,720 (2,565)	Cut to length	1

558402-1

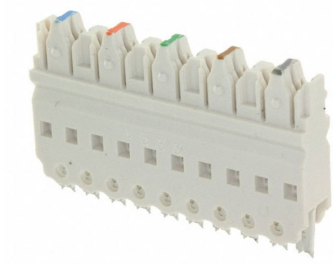

110Connect XC System Connector Block, 5-pair, PCB, 110 punchdown, white

Approved

Jasmine Scinto

04/20/2022

Product Classification

Regional Availability	Asia Australia/New Zealand EMEA Latin America North America
Portfolio	NETCONNECT®
Product Type	Wiring block
Product Series	110 Series

General Specifications

ANSI/TIA Category	5e
Color	Ivory
Pairs, quantity	5
Termination Tool	110 Punchdown tool
Termination Type	IDC

Material Specifications

Material Type	Glass filled polycarbonate
----------------------	----------------------------

Environmental Specifications

Environmental Space	Indoor
----------------------------	--------

Packaging and Weights

Packaging quantity	25
---------------------------	----

Regulatory Compliance/Certifications

Agency	Classification
CHINA-ROHS	Below maximum concentration value

558402-1

REACH-SVHC

Compliant as per SVHC revision on www.commscope.com/ProductCompliance

ROHS

Compliant





110Connect XC System Designation Strip

Approved

Jasmine Scinto

04/20/2022

Product Classification

Regional Availability	Australia/New Zealand EMEA
Portfolio	NETCONNECT®
Product Type	Label holder
Product Series	110 Series

General Specifications

Color	Clear
--------------	-------

Environmental Specifications

Environmental Space	Indoor
----------------------------	--------

Packaging and Weights

Packaging quantity	10
Packaging Type	Box Carton

Regulatory Compliance/Certifications

Agency	Classification
CHINA-ROHS	Below maximum concentration value
REACH-SVHC	Compliant as per SVHC revision on www.commscope.com/ProductCompliance
ROHS	Compliant



558842-1

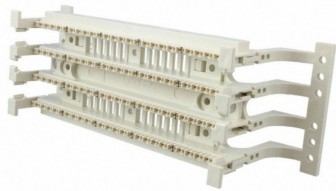

110Connect XC System Cross-Connect Wiring Block with Legs, 100-pair, Category 5e, .110 punch down

Approved

Jasmine Scinto

04/20/2022

Product Classification

Regional Availability	Asia Australia/New Zealand EMEA Latin America North
Portfolio	NETCONNECT®
Product Type	Wiring block
Product Series	110 Series

DA Comment - 110 punch down block to be installed in Telephone Room. Furnish and install voice patch panel in wall cabinet in IT Room #106B.

General Specifications

ANSI/TIA Category	5e
Color	Ivory
Mounting	Backboard
Pairs, quantity	100
Termination Tool	110 Punchdown tool
Termination Type	IDC

Material Specifications

Material Type	Glass filled polycarbonate
----------------------	----------------------------

Environmental Specifications

Environmental Space	Indoor
----------------------------	--------

Packaging and Weights

Packaging quantity	1
Packaging Type	Box Carton

Regulatory Compliance/Certifications

558842-1

Agency

CHINA-ROHS
REACH-SVHC
ROHS

Classification

Below maximum concentration value
Compliant as per SVHC revision on www.commscope.com/ProductCompliance
Compliant



Closet Connector Housing Panels (CCH-CP)

A LANscape® Solutions Product

features and benefits |

Universal design approach	One-size-fits-all LANscape® Solutions housings
Broadest range of fiber count and adapter types	Solutions for all needs
Colored icon labeling	Easy connector identification

Corning Cable Systems Closet Connector Housing Panels (CCH-CP) are offered in a variety of fiber counts for use with LANscape® Solutions hardware products for a “one-size-fits-all” approach. Used with factory-installed or field-installable connectors, these panels provide interconnect or cross-connect capability in a housing at main cross-connects, intermediate cross-connects, telecommunication rooms or work areas. Available with a variety of industry-standard adapter types, the CCH-CP provides an efficient way to securely mate two connectors and offers multimode and single-mode applications in 6-, 8-, 12-, 16- and 24-fiber count options, plus 36-, 72-, 96- and 144-fiber count options with MTP® Connector adapters.

Approved
 Jasmine Scinto
 04/20/2022

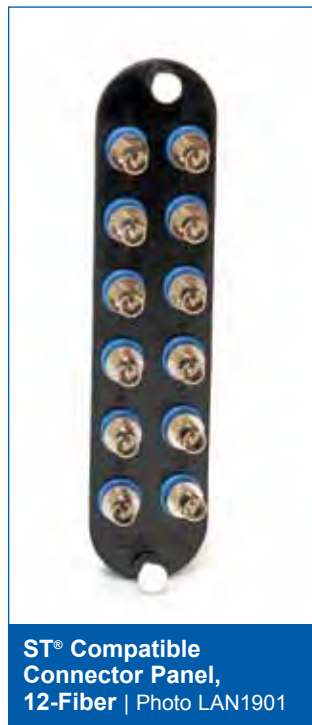

Closet Connector Housing Panels (CCH-CP)

A LANscape®
Solutions Product

ordering information |

CCH - CP -
|1 |2

|1

Select fiber count.

06 = 6 fibers

08 = 8 fibers

12 = 12 fibers

16 = 16 fibers

24 = 24 fibers

36 = 36 fibers

72 = 72 fibers

96 = 96 fibers

E4 = 144 fibers

See Note 1.

|2

Select adapter code
(see Adapter/Connector
Code Options table on
following page).

Note:

1) Fiber count for desired adapter
is available in table on following
page.

Part Number Example

Part Number	Description
CCH-CP12-A9	Closet Connector Housing Pigtail Panel with 6 LC duplex single-mode adapters

Closet Connector Housing Panels (CCH-CP)

A LANscape®
Solutions Product

adapter/connector code options |

Adapter Code	Fiber Type	Alignment	Housing	Fiber/Adapter	Available Fiber/Panel Counts								
					6	8	12	16	24	36	72	96	144
LC Duplex													
A8	62.5 µm multimode (OM1)	Ceramic	Composite	2	X	X	X	X	X				
D3	50 µm multimode (OM2)	Ceramic	Composite	2	X	X	X	X	X				
E4	50 µm multimode (OM3/4)	Ceramic	Composite	2	X	X	X	X	X				
A9	Single-mode, UPC (OS2)	Ceramic	Composite	2	X	X	X	X	X				
B3	Single-mode, APC (OS2)	Ceramic	Composite	2	X	X	X	X	X				
SC Duplex													
91	62.5 µm multimode (OM1)	Metal	Composite	2	X	X	X						
G7	50 µm multimode (OM2)	Ceramic	Composite	2	X	X	X						
E7	50 µm multimode (OM3/4)	Ceramic	Composite	2	X	X	X						
59	Single-mode, UPC (OS2)	Ceramic	Composite	2	X	X	X						
D9	Single-mode, APC (OS2)	Ceramic	Composite	2	X	X	X						
SC													
56	62.5 µm multimode (OM1)	Metal	Composite	1	X	X	X						
G6	50 µm multimode (OM2)	Ceramic	Composite	1	X	X	X						
E6	50 µm multimode (OM3/4)	Ceramic	Composite	1	X	X	X						
3C	Single-mode, UPC (OS2)	Ceramic	Composite	1	X	X	X						
6C	Single-mode, APC (OS2)	Ceramic	Composite	1	X	X	X						
ST® Compatible Connector													
15T	62.5 µm multimode (OM1)	Ceramic	Metal	1	X	X	X						
G5	50 µm multimode (OM2)	Ceramic	Metal	1	X	X	X						
H3	50 µm multimode (OM3/4)	Ceramic	Metal	1	X	X	X						
19T	Single-mode, UPC (OS2)	Ceramic	Metal	1	X	X	X						
FC													
11	Single-mode, UPC (OS2)	Metal	Metal	1	X	X	X						
21	Single-mode, APC (OS2)	Metal	Metal	1	X	X	X						
MT-RJ													
97	62.5 µm multimode (OM1)	N/A	Composite	2		X	X	X	X				
G1	50 µm multimode (OM2)	N/A	Composite	2		X	X	X	X				
E1	50 µm multimode (OM3/4)	N/A	Composite	2		X	X	X	X				
98	Single-mode, UPC (OS2)	N/A	Composite	2		X	X	X	X				
MTP® Connector													
69	62.5 µm multimode (OM1)	N/A	Composite	12						X	X	X	X
G3	50 µm multimode (OM2)	N/A	Composite	12						X	X	X	X
E3	50 µm multimode (OM3/4)	N/A	Composite	12						X	X	X	X
90	Single-mode (OS2)	N/A	Composite	12						X	X	X	X
Fiber Type		Housing Color, Simplex and Duplex			Housing Color, MTP								
62.5 µm multimode (OM1)		Beige			Black								
50 µm multimode (OM2)		Black			Black								
50 µm multimode (OM3/4)		Aqua			Aqua								
Single-mode, UPC (OS2)		Blue			Black								
Single-mode, APC (OS2)		Green			Black								

Closet Connector Housing Panels (CCH-CP)

A LANscape®
Solutions Product

ordering information | (continued)

Colored Icons (pack of 50)

ICN -
|1

|1

Select icon.

Blank Icons



YLB = Blank (Yellow)

RDB = Blank (Red)

GRB = Blank (Green)

BLB = Blank (Blue)

WTB = Blank (White)

BGB = Blank (Beige)

ORB = Blank (Orange)

Etched Icons



BLP = Phone (Blue)



RDC = Computer (Red)



GRT = Cable TV (Green)

Corning Cable Systems LLC • PO Box 489 • Hickory, NC 28603-0489 USA
800-743-2675 • FAX: 828-325-5060 • International: +1-828-901-5000 • www.corning.com/cablesystems

Corning Cable Systems reserves the right to improve, enhance and modify the features and specifications of Corning Cable Systems products without prior notification. LANscape is a registered trademark of Corning Cable Systems Brands, Inc. MTP is a registered trademark of USConec, Ltd. ST is a registered trademark of Lucent Technologies. All other trademarks are the properties of their respective owners. Corning Cable Systems is ISO 9001 certified. ©2007, 2012 Corning Cable Systems. All rights reserved. Published in the USA. LAN-133-EN / February 2012

FuseLite® 2 Splice-on Connector

CORNING

The FuseLite® 2 Splice-On Connector enables fast, reliable fusion splicing connectivity for all networks and offers flexibility for repairs and restoration of connectivity. Available in SC, LC and ST® compatible, the FuseLite2 Connector provides a reliable connectivity option for applications where fusion splicing may be preferred, such as reflectance-sensitive applications. The FuseLite2 Connector eliminates the need for splice trays and is compatible with leading fusion splicers in the market.

Visit www.corning.com or contact Corning Customer Service at 1-800-743-2675 for more information.

Features and Benefits

Broad operating temperature range (-40°C to +75°C)

Utility and flexibility

Factory-polished end face

Consistent optical performance

Fusion splice connectivity

Ideal for reflectance-sensitive applications

Splice protection within connector body

No splice trays required



FuseLite® 2 Splice-on Connector

Approved

Jasmine Scinto

04/20/2022

NING

Standards

RoHS	Free of hazardous substances according to RoHS 2011/65/EU
------	---

Specifications

General Specifications

Keyed (security)	No
Product Type	Field-Installable Connectors
Technology	Fuse-On

Environmental Conditions

Temperature Range, Operation	-40 °C - 75 °C (-40 °F - 167 °F)
------------------------------	----------------------------------

Design Connector

Part Number	Connector Type	Housing Material	Housing Color
FL2-LC-2MM-OM1-25	LC	Composite	Beige
FL2-LC-2MM-OM1-25-TAA	LC	Composite	Beige
FL2-LC-2MM-OM1-6	LC	Composite	Beige
FL2-LC-2MM-OM4-25	LC	Composite	Aqua
FL2-LC-2MM-OM4-25-TAA	LC	Composite	Aqua
FL2-LC-2MM-OM4-6	LC	Composite	Aqua
FL2-LC-900-OM1-25	LC	Composite	Beige
FL2-LC-900-OM1-25-TAA	LC	Composite	Beige
FL2-LC-900-OM1-6	LC	Composite	Beige
FL2-LC-900-OM4-25	LC	Composite	Aqua
FL2-LC-900-OM4-25-TAA	LC	Composite	Aqua
FL2-LC-900-OM4-6	LC	Composite	Aqua
FL2-LCA-2MM-SM-25	LC APC	Composite	Green

FuseLite® 2 Splice-on Connector

CORNING

Design Connector			
Part Number	Connector Type	Housing Material	Housing Color
FL2-LCA-2MM-SM-25-TAA	LC APC	Composite	Green
FL2-LCA-2MM-SM-6	LC APC	Composite	Green
FL2-LCA-900-SM-25	LC APC	Composite	Green
FL2-LCA-900-SM-25-TAA	LC APC	Composite	Green
FL2-LCA-900-SM-6	LC APC	Composite	Green
FL2-LCU-2MM-SM-25	LC UPC	Composite	Blue
FL2-LCU-2MM-SM-25-TAA	LC UPC	Composite	Blue
FL2-LCU-2MM-SM-6	LC UPC	Composite	Blue
FL2-LCU-900-SM-25	LC UPC	Composite	Blue
FL2-LCU-900-SM-25-TAA	LC UPC	Composite	Blue
FL2-LCU-900-SM-6	LC UPC	Composite	Blue
FL2-SC-2-3MM-OM1-25	SC	Composite	Beige
FL2-SC-2-3MM-OM1-25-TAA	SC	Composite	Beige
FL2-SC-2-3MM-OM1-6	SC	Composite	Beige
FL2-SC-2-3MM-OM4-25	SC	Composite	Aqua
FL2-SC-2-3MM-OM4-25-TAA	SC	Composite	Aqua
FL2-SC-2-3MM-OM4-6	SC	Composite	Aqua
FL2-SC-900-OM1-25	SC	Composite	Beige
FL2-SC-900-OM1-25-TAA	SC	Composite	Beige
FL2-SC-900-OM1-6	SC	Composite	Beige
FL2-SC-900-OM4-25	SC	Composite	Aqua
FL2-SC-900-OM4-25-TAA	SC	Composite	Aqua
FL2-SC-900-OM4-6	SC	Composite	Aqua
FL2-SCA-2-3MM-SM-25	SC APC	Composite	Green
FL2-SCA-2-3MM-SM-25-TAA	SC APC	Composite	Green
FL2-SCA-2-3MM-SM-6	SC APC	Composite	Green
FL2-SCA-900-SM-25	SC APC	Composite	Green
FL2-SCA-900-SM-25-TAA	SC APC	Composite	Green

FuseLite® 2 Splice-on Connector

CORNING

Design Connector

Part Number	Connector Type	Housing Material	Housing Color
FL2-SCA-900-SM-6	SC APC	Composite	Green
FL2-SCU-2-3MM-SM-25	SC UPC	Composite	Blue
FL2-SCU-2-3MM-SM-25-TAA	SC UPC	Composite	Blue
FL2-SCU-2-3MM-SM-6	SC UPC	Composite	Blue
FL2-SCU-900-SM-25	SC UPC	Composite	Blue
FL2-SCU-900-SM-25-TAA	SC UPC	Composite	Blue
FL2-SCU-900-SM-6	SC UPC	Composite	Blue

Optical Specifications Connector

Part Number	Fiber Category	Insertion Loss, Typical	Insertion Loss, Max.	Reflectance
FL2-LC-2MM-OM4-25	50 µm MM (OM4)	0.2 dB	0.3 dB	≤ -30 db
FL2-LC-2MM-OM4-25-TAA	50 µm MM (OM4)	0.2 dB	0.3 dB	≤ -30 db
FL2-LC-2MM-OM4-6	50 µm MM (OM4)	0.2 dB	0.3 dB	≤ -30 db
FL2-LC-900-OM4-25	50 µm MM (OM4)	0.2 dB	0.3 dB	≤ -30 db
FL2-LC-900-OM4-25-TAA	50 µm MM (OM4)	0.2 dB	0.3 dB	≤ -30 db
FL2-LC-900-OM4-6	50 µm MM (OM4)	0.2 dB	0.3 dB	≤ -30 db
FL2-SC-2-3MM-OM4-25	50 µm MM (OM4)	0.2 dB	0.3 dB	≤ -30 db
FL2-SC-2-3MM-OM4-25-TAA	50 µm MM (OM4)	0.2 dB	0.3 dB	≤ -30 db
FL2-SC-2-3MM-OM4-6	50 µm MM (OM4)	0.2 dB	0.3 dB	≤ -30 db
FL2-SC-900-OM4-25	50 µm MM (OM4)	0.2 dB	0.3 dB	≤ -30 db
FL2-SC-900-OM4-25-TAA	50 µm MM (OM4)	0.2 dB	0.3 dB	≤ -30 db
FL2-SC-900-OM4-6	50 µm MM (OM4)	0.2 dB	0.3 dB	≤ -30 db
FL2-LC-2MM-OM1-25	62.5 µm MM (OM1)	0.2 dB	0.3 dB	≤ -30 db
FL2-LC-2MM-OM1-25-TAA	62.5 µm MM (OM1)	0.2 dB	0.3 dB	≤ -30 db
FL2-LC-2MM-OM1-6	62.5 µm MM (OM1)	0.2 dB	0.3 dB	≤ -30 db
FL2-LC-900-OM1-25	62.5 µm MM (OM1)	0.2 dB	0.3 dB	≤ -30 db
FL2-LC-900-OM1-25-TAA	62.5 µm MM (OM1)	0.2 dB	0.3 dB	≤ -30 db

FuseLite® 2 Splice-on Connector

CORNING

Optical Specifications Connector

Part Number	Fiber Category	Insertion Loss, Typical	Insertion Loss, Max.	Reflectance
FL2-LC-900-OM1-6	62.5 μm MM (OM1)	0.2 dB	0.3 dB	≤ -30 db
FL2-SC-2-3MM-OM1-25	62.5 μm MM (OM1)	0.2 dB	0.3 dB	≤ -30 db
FL2-SC-2-3MM-OM1-25-TAA	62.5 μm MM (OM1)	0.2 dB	0.3 dB	≤ -30 db
FL2-SC-2-3MM-OM1-6	62.5 μm MM (OM1)	0.2 dB	0.3 dB	≤ -30 db
FL2-SC-900-OM1-25	62.5 μm MM (OM1)	0.2 dB	0.3 dB	≤ -30 db
FL2-SC-900-OM1-25-TAA	62.5 μm MM (OM1)	0.2 dB	0.3 dB	≤ -30 db
FL2-SC-900-OM1-6	62.5 μm MM (OM1)	0.2 dB	0.3 dB	≤ -30 db
FL2-LCA-2MM-SM-25	Single-mode (OS2)	0.2 dB	0.3 dB	≤ -60 db
FL2-LCA-2MM-SM-25-TAA	Single-mode (OS2)	0.2 dB	0.3 dB	≤ -60 db
FL2-LCA-2MM-SM-6	Single-mode (OS2)	0.2 dB	0.3 dB	≤ -60 db
FL2-LCA-900-SM-25	Single-mode (OS2)	0.2 dB	0.3 dB	≤ -60 db
FL2-LCA-900-SM-25-TAA	Single-mode (OS2)	0.2 dB	0.3 dB	≤ -60 db
FL2-LCA-900-SM-6	Single-mode (OS2)	0.2 dB	0.3 dB	≤ -60 db
FL2-LCU-2MM-SM-25	Single-mode (OS2)	0.2 dB	0.3 dB	≤ -50 dB
FL2-LCU-2MM-SM-25-TAA	Single-mode (OS2)	0.2 dB	0.3 dB	≤ -50 dB
FL2-LCU-2MM-SM-6	Single-mode (OS2)	0.2 dB	0.3 dB	≤ -50 dB
FL2-LCU-900-SM-25	Single-mode (OS2)	0.2 dB	0.3 dB	≤ -50 dB
FL2-LCU-900-SM-25-TAA	Single-mode (OS2)	0.2 dB	0.3 dB	≤ -50 dB
FL2-LCU-900-SM-6	Single-mode (OS2)	0.2 dB	0.3 dB	≤ -50 dB
FL2-SCA-2-3MM-SM-25	Single-mode (OS2)	0.2 dB	0.3 dB	≤ -60 db
FL2-SCA-2-3MM-SM-25-TAA	Single-mode (OS2)	0.2 dB	0.3 dB	≤ -60 db
FL2-SCA-2-3MM-SM-6	Single-mode (OS2)	0.2 dB	0.3 dB	≤ -60 db
FL2-SCA-900-SM-25	Single-mode (OS2)	0.2 dB	0.3 dB	≤ -60 db
FL2-SCA-900-SM-25-TAA	Single-mode (OS2)	0.2 dB	0.3 dB	≤ -60 db
FL2-SCA-900-SM-6	Single-mode (OS2)	0.2 dB	0.3 dB	≤ -60 db
FL2-SCU-2-3MM-SM-25	Single-mode (OS2)	0.2 dB	0.3 dB	≤ -50 dB
FL2-SCU-2-3MM-SM-25-TAA	Single-mode (OS2)	0.2 dB	0.3 dB	≤ -50 dB
FL2-SCU-2-3MM-SM-6	Single-mode (OS2)	0.2 dB	0.3 dB	≤ -50 dB

FuseLite® 2 Splice-on Connector

CORNING

Optical Specifications Connector

Part Number	Fiber Category	Insertion Loss, Typical	Insertion Loss, Max.	Reflectance
FL2-SCU-900-SM-25	Single-mode (OS2)	0.2 dB	0.3 dB	≤ -50 dB
FL2-SCU-900-SM-25-TAA	Single-mode (OS2)	0.2 dB	0.3 dB	≤ -50 dB
FL2-SCU-900-SM-6	Single-mode (OS2)	0.2 dB	0.3 dB	≤ -50 dB

Ordering Information

Part Number	Units per Delivery	Package Contents	Packaging
FL2-LC-2MM-OM1-25	25/1	FuseLite® 2 Splice-on Connector, LC, 2 mm, multimode (OM1)	Bulk Pack
FL2-LC-2MM-OM1-25-TAA	25/1	FuseLite® 2 Splice-on Connector, LC, 2 mm, multimode (OM1), TAA	Bulk Pack
FL2-LC-2MM-OM4-25	25/1	FuseLite® 2 Splice-on Connector, LC, 2 mm, multimode (OM4)	Bulk Pack
FL2-LC-2MM-OM4-25-TAA	25/1	FuseLite® 2 Splice-on Connector, LC, 2 mm, multimode (OM4), TAA	Bulk Pack
FL2-LC-900-OM1-25	25/1	FuseLite® 2 Splice-on Connector, LC, 900 μm, multimode (OM1)	Bulk Pack
FL2-LC-900-OM1-25-TAA	25/1	FuseLite® 2 Splice-on Connector, LC, 900 μm, multimode (OM1), TAA	Bulk Pack
FL2-LC-900-OM4-25	25/1	FuseLite® 2 Splice-on Connector, LC, 900 μm, multimode (OM4)	Bulk Pack
FL2-LC-900-OM4-25-TAA	25/1	FuseLite® 2 Splice-on Connector, LC, 900 μm, multimode (OM4), TAA	Bulk Pack
FL2-LCA-2MM-SM-25	25/1	FuseLite® 2 Splice-on Connector, LC APC, 2 mm, Single-mode (OS2)	Bulk Pack
FL2-LCA-2MM-SM-25-TAA	25/1	FuseLite® 2 Splice-on Connector, LC APC, 2 mm, Single-mode (OS2), TAA	Bulk Pack
FL2-LCA-900-SM-25	25/1	FuseLite® 2 Splice-on Connector, LC APC, 900 μm, Single-mode (OS2)	Bulk Pack
FL2-LCA-900-SM-25-TAA	25/1	FuseLite® 2 Splice-on Connector, LC APC, 900 μm, Single-mode (OS2), TAA	Bulk Pack
FL2-LCU-2MM-SM-25	25/1	FuseLite® 2 Splice-on Connector, LC UPC, 2 mm, Single-mode (OS2)	Bulk Pack

FuseLite® 2 Splice-on Connector

CORNING

Part Number	Units per Delivery	Package Contents	Packaging
FL2-LCU-2MM-SM-25-TAA	25/1	FuseLite® 2 Splice-on Connector, LC UPC, 2 mm, Single-mode (OS2), TAA	Bulk Pack
FL2-LCU-900-SM-25	25/1	FuseLite® 2 Splice-on Connector, LC UPC, 900 µm, Single-mode (OS2)	Bulk Pack
FL2-LCU-900-SM-25-TAA	25/1	FuseLite® 2 Splice-on Connector, LC UPC, 900 µm, Single-mode (OS2), TAA	Bulk Pack
FL2-SC-2-3MM-OM1-25	25/1	FuseLite® 2 Splice-on Connector, SC, 2-3 mm, multimode (OM1)	Bulk Pack
FL2-SC-2-3MM-OM1-25-TAA	25/1	FuseLite® 2 Splice-on Connector, SC, 2-3 mm, multimode (OM1), TAA	Bulk Pack
FL2-SC-2-3MM-OM4-25	25/1	FuseLite® 2 Splice-on Connector, SC, 2-3 mm, multimode (OM4)	Bulk Pack
FL2-SC-2-3MM-OM4-25-TAA	25/1	FuseLite® 2 Splice-on Connector, SC, 2-3 mm, multimode (OM4), TAA	Bulk Pack
FL2-SC-900-OM1-25	25/1	FuseLite® 2 Splice-on Connector, SC, 900 µm, multimode (OM1)	Bulk Pack
FL2-SC-900-OM1-25-TAA	25/1	FuseLite® 2 Splice-on Connector, SC, 900 µm, multimode (OM1), TAA	Bulk Pack
FL2-SC-900-OM4-25	25/1	FuseLite® 2 Splice-on Connector, SC, 900 µm, multimode (OM4)	Bulk Pack
FL2-SC-900-OM4-25-TAA	25/1	FuseLite® 2 Splice-on Connector, SC, 900 µm, multimode (OM4), TAA	Bulk Pack
FL2-SCA-2-3MM-SM-25	25/1	FuseLite® 2 Splice-on Connector, SC APC, 2-3 mm, Single-mode (OS2)	Bulk Pack
FL2-SCA-2-3MM-SM-25-TAA	25/1	FuseLite® 2 Splice-on Connector, SC APC, 2-3 mm, Single-mode (OS2), TAA	Bulk Pack
FL2-SCA-900-SM-25	25/1	FuseLite® 2 Splice-on Connector, SC APC, 900 µm, Single-mode (OS2)	Bulk Pack
FL2-SCA-900-SM-25-TAA	25/1	FuseLite® 2 Splice-on Connector, SC APC, 900 µm, Single-mode (OS2), TAA	Bulk Pack
FL2-SCU-2-3MM-SM-25	25/1	FuseLite® 2 Splice-on Connector, SC UPC, 2-3 mm, Single-mode (OS2)	Bulk Pack
FL2-SCU-2-3MM-SM-25-TAA	25/1	FuseLite® 2 Splice-on Connector, SC UPC, 2-3 mm, Single-mode (OS2), TAA	Bulk Pack
FL2-SCU-900-SM-25	25/1	FuseLite® 2 Splice-on Connector, SC UPC, 900 µm, Single-mode (OS2)	Bulk Pack

FuseLite® 2 Splice-on Connector



Part Number	Units per Delivery	Package Contents	Packaging
FL2-SCU-900-SM-25-TAA	25/1	FuseLite® 2 Splice-on Connector, SC UPC, 900 µm, Single-mode (OS2), TAA	Bulk Pack
FL2-LC-2MM-OM1-6	6/1	FuseLite® 2 Splice-on Connector, LC, 2 mm, multimode (OM1)	Bulk Pack
FL2-LC-2MM-OM4-6	6/1	FuseLite® 2 Splice-on Connector, LC, 2 mm, multimode (OM4)	Bulk Pack
FL2-LC-900-OM1-6	6/1	FuseLite® 2 Splice-on Connector, LC, 900 µm, multimode (OM1)	Bulk Pack
FL2-LC-900-OM4-6	6/1	FuseLite® 2 Splice-on Connector, LC, 900 µm, multimode (OM4)	Bulk Pack
FL2-LCA-2MM-SM-6	6/1	FuseLite® 2 Splice-on Connector, LC APC, 2 mm, Single-mode (OS2)	Bulk Pack
FL2-LCA-900-SM-6	6/1	FuseLite® 2 Splice-on Connector, LC APC, 900 µm, Single-mode (OS2)	Bulk Pack
FL2-LCU-2MM-SM-6	6/1	FuseLite® 2 Splice-on Connector, LC UPC, 2 mm, Single-mode (OS2)	Bulk Pack
FL2-LCU-900-SM-6	6/1	FuseLite® 2 Splice-on Connector, LC UPC, 900 µm, Single-mode (OS2)	Bulk Pack
FL2-SC-2-3MM-OM1-6	6/1	FuseLite® 2 Splice-on Connector, SC, 2-3 mm, multimode (OM1)	Bulk Pack
FL2-SC-2-3MM-OM4-6	6/1	FuseLite® 2 Splice-on Connector, SC, 2-3 mm, multimode (OM4)	Bulk Pack
FL2-SC-900-OM1-6	6/1	FuseLite® 2 Splice-on Connector, SC, 900 µm, multimode (OM1)	Bulk Pack
FL2-SC-900-OM4-6	6/1	FuseLite® 2 Splice-on Connector, SC, 900 µm, multimode (OM4)	Bulk Pack
FL2-SCA-2-3MM-SM-6	6/1	FuseLite® 2 Splice-on Connector, SC APC, 2-3 mm, Single-mode (OS2)	Bulk Pack
FL2-SCA-900-SM-6	6/1	FuseLite® 2 Splice-on Connector, SC APC, 900 µm, Single-mode (OS2)	Bulk Pack
FL2-SCU-2-3MM-SM-6	6/1	FuseLite® 2 Splice-on Connector, SC UPC, 2-3 mm, Single-mode (OS2)	Bulk Pack
FL2-SCU-900-SM-6	6/1	FuseLite® 2 Splice-on Connector, SC UPC, 900 µm, Single-mode (OS2)	Bulk Pack

FuseLite® 2 Splice-on Connector

The CORNING logo is a dark blue square with the word "CORNING" in white, uppercase, sans-serif font centered within it.

Corning Optical Communications LLC • 4200 Corning Place • Charlotte, NC • 28216 • United States
800-743-2675 • FAX: 828-325-5060 • International: +1-828-901-5000 • www.corning.com/opcomm

A complete listing of the trademarks of Corning Optical Communications is available at www.corning.com/opcomm/trademarks. All other trademarks are the properties of their respective owners. Corning Optical Communications is ISO 9001 certified. © 2020 Corning Optical Communications. All rights reserved.

MIC® Tight-Buffered, Interlocking Armored Cable, Plenum

12 F, 50 µm multimode (OM4)

Approved

Jasmine Scinto

04/20/2022

Corning Cable Systems MIC® Interlocking Armored Plenum Cables are designed for use in plenum, riser and general purpose environments for intrabuilding backbone and horizontal installations. These multifiber cables use individually jacketed TBII® Buffered Fibers enabling easy, consistent stripping and facilitating termination. The fibers are grouped into jacketed subunits and surrounded by a dielectric central member.

The core is protected by a flexible, spirally wrapped, aluminum interlocking armor that offers easy, one-step installation and over seven times the crush protection of unarmored cables. With a flame-retardant outer jacket, this cable is particularly useful for heavy traffic or more challenging mechanical exposure conditions and applications requiring extra rugged cables.

This cable is available in 12 different jacket colors - blue, orange, green, brown, slate, white, red, black, yellow, purple, rose and aqua. The colored jacket allows for easy visual identification of the cables. The standard jacket color will be determined by the dominant fiber type in the cable and will use the standard part numbers shown here. Contact Customer Care at 1-800-743-2675 to order other color options.

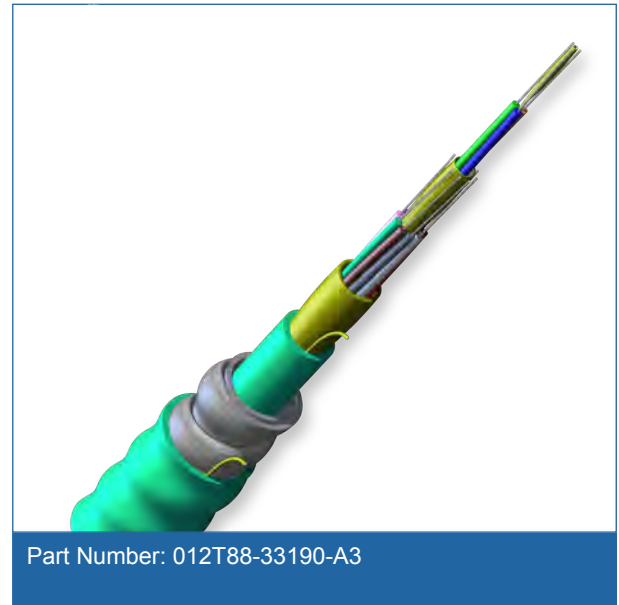

Features and Benefits

Flexible, interlocking armor design

Seven times crush protection compared to unarmored cables

TBII® Buffered Fibers

Easy, consistent stripping

Flame-retardant jacket

Rugged and durable

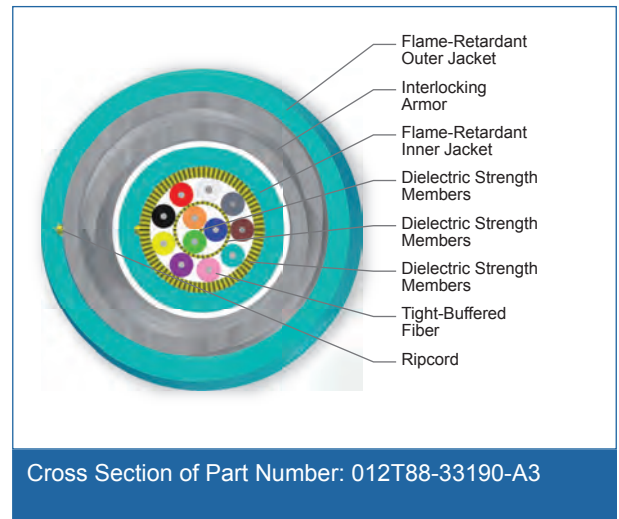

Standards

Approval and Listings

National Electrical Code® (NEC®) OFCP, CSA FT-6, ICEA S-83-596

Flame Resistance

NFPA 262 (for plenum, riser and general building applications)

MIC[®] Tight-Buffered, Interlocking Armored Cable, Plenum

12 F, 50 µm multimode (OM4)

CORNING

Specifications

General Specifications	
Environment	Indoor
Application	General Purpose Horizontal, Vertical Riser, Plenum
Cable Type	Tight-Buffered
Product Type	Interlocking armor
Flame Rating	Plenum (OFCP)
Fiber Category	50 µm MM (OM4)

Temperature Range	
Storage	-40 °C to 70 °C (-40 °F to 158 °F)
Installation	0 °C to 60 °C (32 °F to 140 °F)
Operation	0 °C to 70 °C (32 °F to 158 °F)

Cable Design	
Central Element	Yarn
Fiber Count	12
Tight Buffer Color	Blue, Orange, Green
Tensile Strength Elements and/or Armoring - Layer 1	Dielectric strength members
Tight Buffer Color, Layer 2	Brown, Slate, White, Red, Black, Yellow, Violet, Rose, Aqua
Tensile Strength Elements and/or Armoring - Layer 2	Dielectric strength members
Number of Ripcords	2
Inner Jacket Material	Flame-retardant
Tensile Strength Elements and/or Armoring - Layer 3	Interlocking armor
Outer Jacket Material	Flame-retardant
Outer Jacket Color	Aqua

Mechanical Characteristics Cable	
Nominal Inner Cable Diameter	6.1 mm (0.24 in)
Nominal Outer Diameter	12.6 mm (0.5 in)
Weight	151 kg/km (105 lb/1000 ft)
Max. Tensile Strengths, Short-Term	440 N (100 lbf)
Max. Tensile Strengths, Long-Term	132 N (30 lbf)

MIC[®] Tight-Buffered, Interlocking Armored Cable, Plenum

12 F, 50 µm multimode (OM4)

CORNING

Mechanical Characteristics Cable

Min. Bend Radius Installation	189 mm (7.4 in)
Min. Bend Radius Operation	126 mm (5 in)

Fiber Specifications

Optical Characteristics (cabled)

Fiber Type	Multimode
Fiber Core Diameter	50 µm
Fiber Category	OM4
Fiber Code	T
Performance Option Code	90
Wavelengths	850 nm / 1300 nm
Maximum Attenuation	2.8 dB/km / 1 dB/km
Min. Overfilled Launch (OFL) Bandwidth	3500 MHz*km / 500 MHz*km
Minimum Effective Modal Bandwidth (EMB)	4700 MHz*km / -
Serial 1 Gigabit Ethernet	1100 m / 600 m
Serial 10 Gigabit Ethernet	550 m / -

* Assumes 1.0 dB maximum total connector/splice loss.

* Meets 0.75 ns optical skew when used in all Corning Cable Systems Plug & Play™/Pretium EDGE® Systems Solutions.

- Notes:
- 1) 50 µm multimode fiber macrobend loss ≤ 0.2 dB at 850 nm for two turns around 7.5 mm radius mandrel.
 - 2) Improved attenuation and bandwidth options available.
 - 3) Bend-insensitive single-mode fibers available on request.
 - 4) Contact a Corning Cable Systems Customer Care Representative for additional information.

Ordering Information

Part Number	012T88-33190-A3
Product Description	MIC [®] Tight-Buffered, Interlocking Armored Cable, Plenum, 12 F, 50 µm multimode (OM4)



Corning Cable Systems LLC • PO Box 489 • Hickory, NC 28603-0489 USA

800-743-2675 • FAX: 828-325-5060 • International: +1-828-901-5000 • www.corning.com/cablesystems

A complete listing of the trademarks of Corning Cable Systems is available at www.corning.com/cablesystems/trademarks.

Corning Cable Systems is ISO 9001 certified. © 2012 Corning Cable Systems. All rights reserved.

Closet Connector Housing Panels (CCH-CP)

A LANscape® Solutions Product

features and benefits |

Universal design approach	One-size-fits-all LANscape® Solutions housings
Broadest range of fiber count and adapter types	Solutions for all needs
Colored icon labeling	Easy connector identification

Corning Cable Systems Closet Connector Housing Panels (CCH-CP) are offered in a variety of fiber counts for use with LANscape® Solutions hardware products for a “one-size-fits-all” approach. Used with factory-installed or field-installable connectors, these panels provide interconnect or cross-connect capability in a housing at main cross-connects, intermediate cross-connects, telecommunication rooms or work areas. Available with a variety of industry-standard adapter types, the CCH-CP provides an efficient way to securely mate two connectors and offers multimode and single-mode applications in 6-, 8-, 12-, 16- and 24-fiber count options, plus 36-, 72-, 96- and 144-fiber count options with MTP® Connector adapters.

Approved
 Jasmine Scinto
 04/20/2022

DA Comment - see highlights specified below



Closet Connector Housing Panels (CCH-CP)

A LANscape®
Solutions Product

ordering information |

CCH - CP -
|1 |2

|1

Select fiber count.

06 = 6 fibers

08 = 8 fibers

12 = 12 fibers

16 = 16 fibers

24 = 24 fibers

36 = 36 fibers

72 = 72 fibers

96 = 96 fibers

E4 = 144 fibers

See Note 1.

|2

Select adapter code
(see Adapter/Connector
Code Options table on
following page).

Note:

1) Fiber count for desired adapter
is available in table on following
page.

Part Number Example

Part Number	Description
CCH-CP12-A9	Closet Connector Housing Pigtail Panel with 6 LC duplex single-mode adapters

Closet Connector Housing Panels (CCH-CP)

A LANscape®
Solutions Product

adapter/connector code options |

Adapter Code	Fiber Type	Alignment	Housing	Fiber/Adapter	Available Fiber/Panel Counts								
					6	8	12	16	24	36	72	96	144
LC Duplex													
A8	62.5 µm multimode (OM1)	Ceramic	Composite	2	X	X	X	X	X				
D3	50 µm multimode (OM2)	Ceramic	Composite	2	X	X	X	X	X				
E4	50 µm multimode (OM3/4)	Ceramic	Composite	2	X	X	X	X	X				
A9	Single-mode, UPC (OS2)	Ceramic	Composite	2	X	X	X	X	X				
B3	Single-mode, APC (OS2)	Ceramic	Composite	2	X	X	X	X	X				
SC Duplex													
91	62.5 µm multimode (OM1)	Metal	Composite	2	X	X	X						
G7	50 µm multimode (OM2)	Ceramic	Composite	2	X	X	X						
E7	50 µm multimode (OM3/4)	Ceramic	Composite	2	X	X	X						
59	Single-mode, UPC (OS2)	Ceramic	Composite	2	X	X	X						
D9	Single-mode, APC (OS2)	Ceramic	Composite	2	X	X	X						
SC													
56	62.5 µm multimode (OM1)	Metal	Composite	1	X	X	X						
G6	50 µm multimode (OM2)	Ceramic	Composite	1	X	X	X						
E6	50 µm multimode (OM3/4)	Ceramic	Composite	1	X	X	X						
3C	Single-mode, UPC (OS2)	Ceramic	Composite	1	X	X	X						
6C	Single-mode, APC (OS2)	Ceramic	Composite	1	X	X	X						
ST® Compatible Connector													
15T	62.5 µm multimode (OM1)	Ceramic	Metal	1	X	X	X						
G5	50 µm multimode (OM2)	Ceramic	Metal	1	X	X	X						
H3	50 µm multimode (OM3/4)	Ceramic	Metal	1	X	X	X						
19T	Single-mode, UPC (OS2)	Ceramic	Metal	1	X	X	X						
FC													
11	Single-mode, UPC (OS2)	Metal	Metal	1	X	X	X						
21	Single-mode, APC (OS2)	Metal	Metal	1	X	X	X						
MT-RJ													
97	62.5 µm multimode (OM1)	N/A	Composite	2		X	X	X	X				
G1	50 µm multimode (OM2)	N/A	Composite	2		X	X	X	X				
E1	50 µm multimode (OM3/4)	N/A	Composite	2		X	X	X	X				
98	Single-mode, UPC (OS2)	N/A	Composite	2		X	X	X	X				
MTP® Connector													
69	62.5 µm multimode (OM1)	N/A	Composite	12						X	X	X	X
G3	50 µm multimode (OM2)	N/A	Composite	12						X	X	X	X
E3	50 µm multimode (OM3/4)	N/A	Composite	12						X	X	X	X
90	Single-mode (OS2)	N/A	Composite	12						X	X	X	X
Fiber Type		Housing Color, Simplex and Duplex			Housing Color, MTP								
62.5 µm multimode (OM1)		Beige			Black								
50 µm multimode (OM2)		Black			Black								
50 µm multimode (OM3/4)		Aqua			Aqua								
Single-mode, UPC (OS2)		Blue			Black								
Single-mode, APC (OS2)		Green			Black								

Closet Connector Housing Panels (CCH-CP)

A LANscape®
Solutions Product

ordering information | (continued)

Colored Icons (pack of 50)

ICN -
|1

|1

Select icon.

Blank Icons



YLB = Blank (Yellow)
RDB = Blank (Red)
GRB = Blank (Green)
BLB = Blank (Blue)
WTB = Blank (White)
BGB = Blank (Beige)
ORB = Blank (Orange)

Etched Icons



BLP = Phone (Blue)



RDC = Computer (Red)



GRT = Cable TV (Green)

Corning Cable Systems LLC • PO Box 489 • Hickory, NC 28603-0489 USA
800-743-2675 • FAX: 828-325-5060 • International: +1-828-901-5000 • www.corning.com/cablesystems

Corning Cable Systems reserves the right to improve, enhance and modify the features and specifications of Corning Cable Systems products without prior notification. LANscape is a registered trademark of Corning Cable Systems Brands, Inc. MTP is a registered trademark of USConec, Ltd. ST is a registered trademark of Lucent Technologies. All other trademarks are the properties of their respective owners. Corning Cable Systems is ISO 9001 certified. ©2007, 2012 Corning Cable Systems. All rights reserved. Published in the USA. LAN-133-EN / February 2012

PART NUMBERS AND PHYSICAL CHARACTERISTICS

Listing	Part Number	Pair Count	Jacket Color	Nominal Diameter in (mm)	Approx. Weight lbs/kft (kg/km)	Package	Packages per Pallet
CMR	18-042-13	2	Beige	0.12 (3.1)	9 (13)	1,000' POP™ box	45
CMR	18-042-33	2	Gray	0.12 (3.1)	9 (13)	1,000' POP box	45
CMR	18-141-13	3	Beige	0.14 (3.5)	12 (18)	1,000' POP box	45
CMR	18-141-33	3	Gray	0.14 (3.5)	12 (18)	1,000' POP box	45
CMR	18-241-13	4	Beige	0.16 (3.9)	15 (22)	1,000' POP box	45
CMR	18-241-23	4	Blue	0.16 (3.9)	15 (22)	1,000' POP box	45
CMR	18-241-33	4	Gray	0.16 (3.9)	15 (22)	1,000' POP box	45
CMR	18-241-43	4	White	0.16 (3.9)	15 (22)	1,000' POP box	45
CMR	18-341-13	6	Beige	0.19 (4.8)	22 (32)	1,000' POP box	45
CMR	18-341-33	6	Gray	0.19 (4.8)	22 (32)	1,000' POP box	45
CMR	18-872-13	12	Beige	0.27 (6.9)	47 (71)	1,000' Plywood reel	16
CMR	18-872-33	12	Gray	0.27 (6.9)	47 (71)	1,000' Plywood reel	16
CMR	18-475-13	25	Beige	0.38 (9.6)	92 (137)	1,000' Plywood reel	12
CMR	18-499-13	25	Beige	0.38 (9.6)	92 (137)	Cut to length	1
CMR	18-475-33	25	Gray	0.38 (9.6)	92 (137)	1,000' Plywood reel	12
CMR	18-499-33	25	Gray	0.38 (9.6)	92 (137)	Cut to length	1
CMR	18-579-13	50	Beige	0.56 (14.2)	187 (279)	1,000' Plywood reel	4
CMR	18-599-13	50	Beige	0.56 (14.2)	187 (279)	Cut to length	1
CMR	18-579-33	50	Gray	0.56 (14.2)	187 (279)	1,000' Plywood reel	4
CMR	18-599-33	50	Gray	0.56 (14.2)	187 (279)	Cut to length	1
CMR	18-789-13	100	Beige	0.74 (18.7)	361 (538)	Cut to length	1
CMR	18-789-33	100	Gray	0.74 (18.7)	361 (538)	Cut to length	1
CMR	18-D99-33	150	Gray	0.92 (23.4)	541 (807)	Cut to length	1
CMR	18-A99-33	200	Gray	1.05 (26.6)	711 (1,060)	Cut to length	1
CMR	18-B99-33	300	Gray	1.27 (32.2)	1,049 (1,564)	Cut to length	1
CMR	18-C99-33	400	Gray	1.45 (36.9)	1,386 (2,067)	Cut to length	1
CMP	18-041-36	2	Gray	0.13 (3.3)	10 (15)	1,000' POP box	45
CMP	18-141-36	3	Gray	0.15 (3.7)	14 (20)	1,000' POP box	45
CMP	18-241-26	4	Blue	0.16 (4.2)	17 (26)	1,000' POP box	45
CMP	18-241-36	4	Gray	0.16 (4.2)	17 (26)	1,000' POP box	45
CMP	18-241-46	4	White	0.16 (4.2)	17 (26)	1,000' POP box	45
CMP	18-241-56	4	Green	0.16 (4.2)	17 (26)	1,000' POP box	45
CMP	18-341-36	6	Gray	0.20 (5.0)	24 (37)	1,000' POP box	45
CMP	18-341-46	6	White	0.20 (5.0)	24 (37)	1,000' POP box	45
CMP	18-872-46	12	White	0.30 (7.6)	49 (73)	1,000' Plywood reel	16
CMP	18-475-36	25	Gray	0.43 (10.9)	114 (171)	1,000' Plywood reel	12
CMP	18-499-36	25	Gray	0.43 (10.9)	114 (171)	Cut to length	1
CMP	18-475-46	25	White	0.43 (10.9)	114 (171)	1,000' Plywood reel	12
CMP	18-499-46	25	White	0.43 (10.9)	114 (171)	Cut to length	1
CMP	18-579-36	50	Gray	0.60 (15.3)	227 (339)	1,000' Plywood reel	4
CMP	18-599-36	50	Gray	0.60 (15.3)	227 (339)	Cut to length	1
CMP	18-799-36	100	Gray	0.84 (21.3)	446 (665)	Cut to length	1
CMP	18-799-46	100	White	0.84 (21.3)	446 (666)	Cut to length	1
CMP	18-A99-36	200	Gray	1.16 (29.4)	850 (1,268)	Cut to length	1
CMP	18-B99-36	300	Gray	1.44 (36.7)	1,315 (1,960)	Cut to length	1
CMP	18-B99-46	300	White	1.44 (36.7)	1,315 (1,961)	Cut to length	1
CMP	18-C99-36	400	Gray	1.64 (41.7)	1,720 (2,565)	Cut to length	1

FuseLite® 2 Splice-on Connector



The FuseLite® 2 Splice-On Connector enables fast, reliable fusion splicing connectivity for all networks and offers flexibility for repairs and restoration of connectivity. Available in SC, LC and ST® compatible, the FuseLite2 Connector provides a reliable connectivity option for applications where fusion splicing may be preferred, such as reflectance-sensitive applications. The FuseLite2 Connector eliminates the need for splice trays and is compatible with leading fusion splicers in the market.

Visit www.corning.com or contact Corning Customer Service at 1-800-743-2675 for more information.

Features and Benefits

Broad operating temperature range (-40°C to +75°C)

Utility and flexibility

Factory-polished end face

Consistent optical performance

Fusion splice connectivity

Ideal for reflectance-sensitive applications

Splice protection within connector body

No splice trays required



FuseLite® 2 Splice-on Connector

CORNING

Standards

RoHS	Free of hazardous substances according to RoHS 2011/65/EU
------	---

Specifications

General Specifications

Keyed (security)	No
Product Type	Field-Installable Connectors
Technology	Fuse-On

Environmental Conditions

Temperature Range, Operation	-40 °C - 75 °C (-40 °F - 167 °F)
------------------------------	----------------------------------

Design Connector

Part Number	Connector Type	Housing Material	Housing Color
FL2-LC-2MM-OM1-25	LC	Composite	Beige
FL2-LC-2MM-OM1-25-TAA	LC	Composite	Beige
FL2-LC-2MM-OM1-6	LC	Composite	Beige
FL2-LC-2MM-OM4-25	LC	Composite	Aqua
FL2-LC-2MM-OM4-25-TAA	LC	Composite	Aqua
FL2-LC-2MM-OM4-6	LC	Composite	Aqua
FL2-LC-900-OM1-25	LC	Composite	Beige
FL2-LC-900-OM1-25-TAA	LC	Composite	Beige
FL2-LC-900-OM1-6	LC	Composite	Beige
FL2-LC-900-OM4-25	LC	Composite	Aqua
FL2-LC-900-OM4-25-TAA	LC	Composite	Aqua
FL2-LC-900-OM4-6	LC	Composite	Aqua
FL2-LCA-2MM-SM-25	LC APC	Composite	Green

FuseLite® 2 Splice-on Connector

CORNING

Design Connector			
Part Number	Connector Type	Housing Material	Housing Color
FL2-LCA-2MM-SM-25-TAA	LC APC	Composite	Green
FL2-LCA-2MM-SM-6	LC APC	Composite	Green
FL2-LCA-900-SM-25	LC APC	Composite	Green
FL2-LCA-900-SM-25-TAA	LC APC	Composite	Green
FL2-LCA-900-SM-6	LC APC	Composite	Green
FL2-LCU-2MM-SM-25	LC UPC	Composite	Blue
FL2-LCU-2MM-SM-25-TAA	LC UPC	Composite	Blue
FL2-LCU-2MM-SM-6	LC UPC	Composite	Blue
FL2-LCU-900-SM-25	LC UPC	Composite	Blue
FL2-LCU-900-SM-25-TAA	LC UPC	Composite	Blue
FL2-LCU-900-SM-6	LC UPC	Composite	Blue
FL2-SC-2-3MM-OM1-25	SC	Composite	Beige
FL2-SC-2-3MM-OM1-25-TAA	SC	Composite	Beige
FL2-SC-2-3MM-OM1-6	SC	Composite	Beige
FL2-SC-2-3MM-OM4-25	SC	Composite	Aqua
FL2-SC-2-3MM-OM4-25-TAA	SC	Composite	Aqua
FL2-SC-2-3MM-OM4-6	SC	Composite	Aqua
FL2-SC-900-OM1-25	SC	Composite	Beige
FL2-SC-900-OM1-25-TAA	SC	Composite	Beige
FL2-SC-900-OM1-6	SC	Composite	Beige
FL2-SC-900-OM4-25	SC	Composite	Aqua
FL2-SC-900-OM4-25-TAA	SC	Composite	Aqua
FL2-SC-900-OM4-6	SC	Composite	Aqua
FL2-SCA-2-3MM-SM-25	SC APC	Composite	Green
FL2-SCA-2-3MM-SM-25-TAA	SC APC	Composite	Green
FL2-SCA-2-3MM-SM-6	SC APC	Composite	Green
FL2-SCA-900-SM-25	SC APC	Composite	Green
FL2-SCA-900-SM-25-TAA	SC APC	Composite	Green

FuseLite® 2 Splice-on Connector

CORNING

Design Connector

Part Number	Connector Type	Housing Material	Housing Color
FL2-SCA-900-SM-6	SC APC	Composite	Green
FL2-SCU-2-3MM-SM-25	SC UPC	Composite	Blue
FL2-SCU-2-3MM-SM-25-TAA	SC UPC	Composite	Blue
FL2-SCU-2-3MM-SM-6	SC UPC	Composite	Blue
FL2-SCU-900-SM-25	SC UPC	Composite	Blue
FL2-SCU-900-SM-25-TAA	SC UPC	Composite	Blue
FL2-SCU-900-SM-6	SC UPC	Composite	Blue

Optical Specifications Connector

Part Number	Fiber Category	Insertion Loss, Typical	Insertion Loss, Max.	Reflectance
FL2-LC-2MM-OM4-25	50 µm MM (OM4)	0.2 dB	0.3 dB	≤ -30 db
FL2-LC-2MM-OM4-25-TAA	50 µm MM (OM4)	0.2 dB	0.3 dB	≤ -30 db
FL2-LC-2MM-OM4-6	50 µm MM (OM4)	0.2 dB	0.3 dB	≤ -30 db
FL2-LC-900-OM4-25	50 µm MM (OM4)	0.2 dB	0.3 dB	≤ -30 db
FL2-LC-900-OM4-25-TAA	50 µm MM (OM4)	0.2 dB	0.3 dB	≤ -30 db
FL2-LC-900-OM4-6	50 µm MM (OM4)	0.2 dB	0.3 dB	≤ -30 db
FL2-SC-2-3MM-OM4-25	50 µm MM (OM4)	0.2 dB	0.3 dB	≤ -30 db
FL2-SC-2-3MM-OM4-25-TAA	50 µm MM (OM4)	0.2 dB	0.3 dB	≤ -30 db
FL2-SC-2-3MM-OM4-6	50 µm MM (OM4)	0.2 dB	0.3 dB	≤ -30 db
FL2-SC-900-OM4-25	50 µm MM (OM4)	0.2 dB	0.3 dB	≤ -30 db
FL2-SC-900-OM4-25-TAA	50 µm MM (OM4)	0.2 dB	0.3 dB	≤ -30 db
FL2-SC-900-OM4-6	50 µm MM (OM4)	0.2 dB	0.3 dB	≤ -30 db
FL2-LC-2MM-OM1-25	62.5 µm MM (OM1)	0.2 dB	0.3 dB	≤ -30 db
FL2-LC-2MM-OM1-25-TAA	62.5 µm MM (OM1)	0.2 dB	0.3 dB	≤ -30 db
FL2-LC-2MM-OM1-6	62.5 µm MM (OM1)	0.2 dB	0.3 dB	≤ -30 db
FL2-LC-900-OM1-25	62.5 µm MM (OM1)	0.2 dB	0.3 dB	≤ -30 db
FL2-LC-900-OM1-25-TAA	62.5 µm MM (OM1)	0.2 dB	0.3 dB	≤ -30 db

FuseLite® 2 Splice-on Connector

CORNING

Optical Specifications Connector

Part Number	Fiber Category	Insertion Loss, Typical	Insertion Loss, Max.	Reflectance
FL2-LC-900-OM1-6	62.5 μm MM (OM1)	0.2 dB	0.3 dB	≤ -30 db
FL2-SC-2-3MM-OM1-25	62.5 μm MM (OM1)	0.2 dB	0.3 dB	≤ -30 db
FL2-SC-2-3MM-OM1-25-TAA	62.5 μm MM (OM1)	0.2 dB	0.3 dB	≤ -30 db
FL2-SC-2-3MM-OM1-6	62.5 μm MM (OM1)	0.2 dB	0.3 dB	≤ -30 db
FL2-SC-900-OM1-25	62.5 μm MM (OM1)	0.2 dB	0.3 dB	≤ -30 db
FL2-SC-900-OM1-25-TAA	62.5 μm MM (OM1)	0.2 dB	0.3 dB	≤ -30 db
FL2-SC-900-OM1-6	62.5 μm MM (OM1)	0.2 dB	0.3 dB	≤ -30 db
FL2-LCA-2MM-SM-25	Single-mode (OS2)	0.2 dB	0.3 dB	≤ -60 db
FL2-LCA-2MM-SM-25-TAA	Single-mode (OS2)	0.2 dB	0.3 dB	≤ -60 db
FL2-LCA-2MM-SM-6	Single-mode (OS2)	0.2 dB	0.3 dB	≤ -60 db
FL2-LCA-900-SM-25	Single-mode (OS2)	0.2 dB	0.3 dB	≤ -60 db
FL2-LCA-900-SM-25-TAA	Single-mode (OS2)	0.2 dB	0.3 dB	≤ -60 db
FL2-LCA-900-SM-6	Single-mode (OS2)	0.2 dB	0.3 dB	≤ -60 db
FL2-LCU-2MM-SM-25	Single-mode (OS2)	0.2 dB	0.3 dB	≤ -50 dB
FL2-LCU-2MM-SM-25-TAA	Single-mode (OS2)	0.2 dB	0.3 dB	≤ -50 dB
FL2-LCU-2MM-SM-6	Single-mode (OS2)	0.2 dB	0.3 dB	≤ -50 dB
FL2-LCU-900-SM-25	Single-mode (OS2)	0.2 dB	0.3 dB	≤ -50 dB
FL2-LCU-900-SM-25-TAA	Single-mode (OS2)	0.2 dB	0.3 dB	≤ -50 dB
FL2-LCU-900-SM-6	Single-mode (OS2)	0.2 dB	0.3 dB	≤ -50 dB
FL2-SCA-2-3MM-SM-25	Single-mode (OS2)	0.2 dB	0.3 dB	≤ -60 db
FL2-SCA-2-3MM-SM-25-TAA	Single-mode (OS2)	0.2 dB	0.3 dB	≤ -60 db
FL2-SCA-2-3MM-SM-6	Single-mode (OS2)	0.2 dB	0.3 dB	≤ -60 db
FL2-SCA-900-SM-25	Single-mode (OS2)	0.2 dB	0.3 dB	≤ -60 db
FL2-SCA-900-SM-25-TAA	Single-mode (OS2)	0.2 dB	0.3 dB	≤ -60 db
FL2-SCA-900-SM-6	Single-mode (OS2)	0.2 dB	0.3 dB	≤ -60 db
FL2-SCU-2-3MM-SM-25	Single-mode (OS2)	0.2 dB	0.3 dB	≤ -50 dB
FL2-SCU-2-3MM-SM-25-TAA	Single-mode (OS2)	0.2 dB	0.3 dB	≤ -50 dB
FL2-SCU-2-3MM-SM-6	Single-mode (OS2)	0.2 dB	0.3 dB	≤ -50 dB

FuseLite® 2 Splice-on Connector

CORNING

Optical Specifications Connector

Part Number	Fiber Category	Insertion Loss, Typical	Insertion Loss, Max.	Reflectance
FL2-SCU-900-SM-25	Single-mode (OS2)	0.2 dB	0.3 dB	≤ -50 dB
FL2-SCU-900-SM-25-TAA	Single-mode (OS2)	0.2 dB	0.3 dB	≤ -50 dB
FL2-SCU-900-SM-6	Single-mode (OS2)	0.2 dB	0.3 dB	≤ -50 dB

Ordering Information

Part Number	Units per Delivery	Package Contents	Packaging
FL2-LC-2MM-OM1-25	25/1	FuseLite® 2 Splice-on Connector, LC, 2 mm, multimode (OM1)	Bulk Pack
FL2-LC-2MM-OM1-25-TAA	25/1	FuseLite® 2 Splice-on Connector, LC, 2 mm, multimode (OM1), TAA	Bulk Pack
FL2-LC-2MM-OM4-25	25/1	FuseLite® 2 Splice-on Connector, LC, 2 mm, multimode (OM4)	Bulk Pack
FL2-LC-2MM-OM4-25-TAA	25/1	FuseLite® 2 Splice-on Connector, LC, 2 mm, multimode (OM4), TAA	Bulk Pack
FL2-LC-900-OM1-25	25/1	FuseLite® 2 Splice-on Connector, LC, 900 μm, multimode (OM1)	Bulk Pack
FL2-LC-900-OM1-25-TAA	25/1	FuseLite® 2 Splice-on Connector, LC, 900 μm, multimode (OM1), TAA	Bulk Pack
FL2-LC-900-OM4-25	25/1	FuseLite® 2 Splice-on Connector, LC, 900 μm, multimode (OM4)	Bulk Pack
FL2-LC-900-OM4-25-TAA	25/1	FuseLite® 2 Splice-on Connector, LC, 900 μm, multimode (OM4), TAA	Bulk Pack
FL2-LCA-2MM-SM-25	25/1	FuseLite® 2 Splice-on Connector, LC APC, 2 mm, Single-mode (OS2)	Bulk Pack
FL2-LCA-2MM-SM-25-TAA	25/1	FuseLite® 2 Splice-on Connector, LC APC, 2 mm, Single-mode (OS2), TAA	Bulk Pack
FL2-LCA-900-SM-25	25/1	FuseLite® 2 Splice-on Connector, LC APC, 900 μm, Single-mode (OS2)	Bulk Pack
FL2-LCA-900-SM-25-TAA	25/1	FuseLite® 2 Splice-on Connector, LC APC, 900 μm, Single-mode (OS2), TAA	Bulk Pack
FL2-LCU-2MM-SM-25	25/1	FuseLite® 2 Splice-on Connector, LC UPC, 2 mm, Single-mode (OS2)	Bulk Pack

FuseLite® 2 Splice-on Connector

CORNING

Part Number	Units per Delivery	Package Contents	Packaging
FL2-LCU-2MM-SM-25-TAA	25/1	FuseLite® 2 Splice-on Connector, LC UPC, 2 mm, Single-mode (OS2), TAA	Bulk Pack
FL2-LCU-900-SM-25	25/1	FuseLite® 2 Splice-on Connector, LC UPC, 900 µm, Single-mode (OS2)	Bulk Pack
FL2-LCU-900-SM-25-TAA	25/1	FuseLite® 2 Splice-on Connector, LC UPC, 900 µm, Single-mode (OS2), TAA	Bulk Pack
FL2-SC-2-3MM-OM1-25	25/1	FuseLite® 2 Splice-on Connector, SC, 2-3 mm, multimode (OM1)	Bulk Pack
FL2-SC-2-3MM-OM1-25-TAA	25/1	FuseLite® 2 Splice-on Connector, SC, 2-3 mm, multimode (OM1), TAA	Bulk Pack
FL2-SC-2-3MM-OM4-25	25/1	FuseLite® 2 Splice-on Connector, SC, 2-3 mm, multimode (OM4)	Bulk Pack
FL2-SC-2-3MM-OM4-25-TAA	25/1	FuseLite® 2 Splice-on Connector, SC, 2-3 mm, multimode (OM4), TAA	Bulk Pack
FL2-SC-900-OM1-25	25/1	FuseLite® 2 Splice-on Connector, SC, 900 µm, multimode (OM1)	Bulk Pack
FL2-SC-900-OM1-25-TAA	25/1	FuseLite® 2 Splice-on Connector, SC, 900 µm, multimode (OM1), TAA	Bulk Pack
FL2-SC-900-OM4-25	25/1	FuseLite® 2 Splice-on Connector, SC, 900 µm, multimode (OM4)	Bulk Pack
FL2-SC-900-OM4-25-TAA	25/1	FuseLite® 2 Splice-on Connector, SC, 900 µm, multimode (OM4), TAA	Bulk Pack
FL2-SCA-2-3MM-SM-25	25/1	FuseLite® 2 Splice-on Connector, SC APC, 2-3 mm, Single-mode (OS2)	Bulk Pack
FL2-SCA-2-3MM-SM-25-TAA	25/1	FuseLite® 2 Splice-on Connector, SC APC, 2-3 mm, Single-mode (OS2), TAA	Bulk Pack
FL2-SCA-900-SM-25	25/1	FuseLite® 2 Splice-on Connector, SC APC, 900 µm, Single-mode (OS2)	Bulk Pack
FL2-SCA-900-SM-25-TAA	25/1	FuseLite® 2 Splice-on Connector, SC APC, 900 µm, Single-mode (OS2), TAA	Bulk Pack
FL2-SCU-2-3MM-SM-25	25/1	FuseLite® 2 Splice-on Connector, SC UPC, 2-3 mm, Single-mode (OS2)	Bulk Pack
FL2-SCU-2-3MM-SM-25-TAA	25/1	FuseLite® 2 Splice-on Connector, SC UPC, 2-3 mm, Single-mode (OS2), TAA	Bulk Pack
FL2-SCU-900-SM-25	25/1	FuseLite® 2 Splice-on Connector, SC UPC, 900 µm, Single-mode (OS2)	Bulk Pack

FuseLite® 2 Splice-on Connector



Part Number	Units per Delivery	Package Contents	Packaging
FL2-SCU-900-SM-25-TAA	25/1	FuseLite® 2 Splice-on Connector, SC UPC, 900 µm, Single-mode (OS2), TAA	Bulk Pack
FL2-LC-2MM-OM1-6	6/1	FuseLite® 2 Splice-on Connector, LC, 2 mm, multimode (OM1)	Bulk Pack
FL2-LC-2MM-OM4-6	6/1	FuseLite® 2 Splice-on Connector, LC, 2 mm, multimode (OM4)	Bulk Pack
FL2-LC-900-OM1-6	6/1	FuseLite® 2 Splice-on Connector, LC, 900 µm, multimode (OM1)	Bulk Pack
FL2-LC-900-OM4-6	6/1	FuseLite® 2 Splice-on Connector, LC, 900 µm, multimode (OM4)	Bulk Pack
FL2-LCA-2MM-SM-6	6/1	FuseLite® 2 Splice-on Connector, LC APC, 2 mm, Single-mode (OS2)	Bulk Pack
FL2-LCA-900-SM-6	6/1	FuseLite® 2 Splice-on Connector, LC APC, 900 µm, Single-mode (OS2)	Bulk Pack
FL2-LCU-2MM-SM-6	6/1	FuseLite® 2 Splice-on Connector, LC UPC, 2 mm, Single-mode (OS2)	Bulk Pack
FL2-LCU-900-SM-6	6/1	FuseLite® 2 Splice-on Connector, LC UPC, 900 µm, Single-mode (OS2)	Bulk Pack
FL2-SC-2-3MM-OM1-6	6/1	FuseLite® 2 Splice-on Connector, SC, 2-3 mm, multimode (OM1)	Bulk Pack
FL2-SC-2-3MM-OM4-6	6/1	FuseLite® 2 Splice-on Connector, SC, 2-3 mm, multimode (OM4)	Bulk Pack
FL2-SC-900-OM1-6	6/1	FuseLite® 2 Splice-on Connector, SC, 900 µm, multimode (OM1)	Bulk Pack
FL2-SC-900-OM4-6	6/1	FuseLite® 2 Splice-on Connector, SC, 900 µm, multimode (OM4)	Bulk Pack
FL2-SCA-2-3MM-SM-6	6/1	FuseLite® 2 Splice-on Connector, SC APC, 2-3 mm, Single-mode (OS2)	Bulk Pack
FL2-SCA-900-SM-6	6/1	FuseLite® 2 Splice-on Connector, SC APC, 900 µm, Single-mode (OS2)	Bulk Pack
FL2-SCU-2-3MM-SM-6	6/1	FuseLite® 2 Splice-on Connector, SC UPC, 2-3 mm, Single-mode (OS2)	Bulk Pack
FL2-SCU-900-SM-6	6/1	FuseLite® 2 Splice-on Connector, SC UPC, 900 µm, Single-mode (OS2)	Bulk Pack

FuseLite® 2 Splice-on Connector

The CORNING logo is a dark blue square with the word "CORNING" in white, uppercase, sans-serif font centered within it.

Corning Optical Communications LLC • 4200 Corning Place • Charlotte, NC • 28216 • United States
800-743-2675 • FAX: 828-325-5060 • International: +1-828-901-5000 • www.corning.com/opcomm

A complete listing of the trademarks of Corning Optical Communications is available at www.corning.com/opcomm/trademarks. All other trademarks are the properties of their respective owners. Corning Optical Communications is ISO 9001 certified. © 2020 Corning Optical Communications. All rights reserved.